

Chapter 2

Cutting Mechanics and Analytical Modeling

2.1 Questions and Answers on Machining Modeling

Prior to the description of the most important modeling methods and their features, it would be helpful to introduce some questions that may come to mind of those who want to use modeling, and attempt to give answers. Although some answers are already given in the previous chapter, a more elaborated approach is presented in this section. The questions raised apply to all kinds of modeling; the answers mostly concern FEM, without excluding all the other methods. In the next chapter some more questions and answers, this time solely for FEM, will be presented.

A first question would be: *what is modeling and what is simulation?* A model can be defined as an abstract system which is equivalent to the real system with respect to key properties and characteristics, and is used for investigations, calculations, explanation of demonstration purposes, which would otherwise be too expensive or not possible. A model permits general statements about elements, structure and behavior of a section of reality. Simulation is an imitation of a dynamic process in a model in order to obtain knowledge which can be transferred to reality. Both definitions, for model and simulation, are quoted from Ref. [1]; the former is from Brockhaus while the latter from VDI Guideline 3663.

An obvious question that may occur or has occurred to everybody reading this text would be: *Why model machining? What is the benefit coming out of this task?* Today, most of the researchers dealing with machining modeling perform it for its predictive ability. Important parameters of machining such as cutting forces, temperatures, chip morphology, strains and stresses can be calculated before actually any cutting is performed on a machine tool. The trial-and-error approach is far more laborious, costly and time-consuming. With modeling, resources are spared, optimization is achieved and cost is reduced. The above do not mean that experimental work is obsolete, since in most cases a validation of the model is needed and the only way to provide it is to actually test model results in real conditions and make comparisons. However, modeling reduces experimental work

considerably. Furthermore, modeling and experiments add to the understanding of fundamental issues of machining theory. This forms a feedback loop vital for machining research since better understanding of the processes results in better models and so on. After all “understanding is the next best thing to the ability to predict” [2]. In a keynote paper by CIRP [3] two different “traditional schools” in machining modeling were identified, namely the one that treats modeling as an engineering necessity and another that treats modeling as a scientific challenge. On the long run both have to produce accurate models for the benefit of industry.

Who is, then, interested in machining modeling operations? The answer is the academia and the industry since there are benefits for both and the one depends on the other.

All these benefits are important and it seems that modeling is the solution for many problems. One may ask: *what are the drawbacks?* The answer is that it is the difficulties rather than the drawbacks that explain why modeling is not a panacea. The question could be rephrased to: *why is it difficult to model machining?* The answer lies in the fact that there are too many variables that need to be taken into account. First of all, there are a lot of machining operations and even though similarities do exist, many factors that are case sensitive make the proposal of a universal model not realistic. Even the orthogonal cutting system and shear plane models that are widely used are under criticism, as will be discussed in the next chapter. In the previous chapter a concise description of some machining operations was given in order to point out the similarities and differences that need to be accounted for in modeling, and that is only for traditional machining operations.

Secondly, difficulties arise from the fact that machining is still one of the least understood manufacturing operations. Machining typically involves very large stresses and strains in a small volume and at a high speed. The mechanisms of chip formation are quite complex, leading to equally complex theories and models that represent these theories. It is true that models always include simplifications in order to adequately embody theory but the danger of oversimplification is lurking. The result would be either inaccurate and thus erroneous results or models applicable for only very specific and confined cases. It should be noted that any kind of model is always applicable within the extremes of its input data. However, the area of application must be as wide as possible in order to have practical use. The mechanics of metal machining are briefly presented in the next paragraph. It can be observed that the application of the theory of plasticity on machining is far more complex than e.g. forming processes.

Finally, the variation of workpiece and tool properties and geometrical characteristics, machining conditions such as cutting speed, feed and depth of cut, the use of cutting fluids and the interaction of all the above in the same system increases the complexity of a model. The above are, generally speaking, the input data required to get a model started. Different input parameters will result in different output, significantly altering cutting forces, temperatures and chip morphology. In 1984 that “Metal Cutting Principles” by M. C. Shaw was published it seemed “next to impossible to predict metal cutting performance” [4], due to the complexity of model inputs and system interactions. This is where modern modeling techniques

come to fill in the gap, as it will be pointed out in [Chaps. 3 and 4](#) that are dedicated to FEM.

After the selection of the process, the properties and characteristics of the cutting tool and the workpiece and the determination of the cutting conditions, *what else is needed to build a model?* This answer depends on the selected kind of modeling. The finite element method for example would require meshing parameters to be determined, boundary conditions to be inserted and, depending on the formulation used, maybe a separation criterion for chip creation simulation, among others. It is obvious that this question cannot be answered unless a modeling technique is first selected.

Next question would be then: *what kind of modeling should one choose?* The answer would be the one that is able to provide a reliable answer to the variable/output that it is looked for, with the available input data. There are five generic categories of modeling techniques available [1], i.e. empirical, analytical, mechanistic, numerical and artificial intelligence modeling. More complex models may require more input data; other models may not be able to predict a required parameter. Note, also, that the interest in predictive machining modeling has changed over the years due to advances in cutting technology. In the early days of metal cutting, tool wear was of utmost importance but nowadays the interest has shifted over to e.g. accuracy and determination of cutting forces, temperatures and the kind of produced chip. Furthermore, industry is interested in high speed machining and is environmentally conscious, requiring cutting fluids reduction or omission. Analytical models may predict output data, i.e. cutting forces, through equations requiring constants of workpiece material taken from databases, verified by experimental work, but the major drawback is that for out-of-the-ordinary cases no reliable results can be acquired. FEM on the other hand can perform coupled thermo-mechanical analysis but requires a considerable amount of computational power to produce accurate results. Artificial Intelligence techniques are usually simpler and faster models but provide results focused on a parameter or a specific area of the workpiece. It is true to say that the selection of the modeling technique depends heavily on information technology parameters, as well. Speaking for Finite Elements, more accurate representations of machining processes, e.g. 3D models, are coming true due to the fact that more powerful computers that can perform complicated calculation at an acceptable time are now available. Commercial software of FEM and especially for machining has qualified this technique to be the first choice for modeling machining operations, for many researchers.

Finally, *why would a model fail?* A model fails when it cannot predict accurately. However, it may also be considered not acceptable if it is not simple or fast enough for practical use. Many reasons may contribute to failure; lack of accurate input data, inadequate inclusion of all important parameters and misuse of a modeling technique are the most common reasons for that, as will be exhibited in the next chapter.

Machining technology cannot rely on the craftsmanship of technicians or time-consuming experiments in order to advance and meet the requirements of modern industry. Nowadays, machining is more science than art. A scientific approach is

required and modeling offers solutions. Modern modeling techniques, such as FEM, in close cooperation with computer advances are able to provide reliable results in a timely manner, justifying the many publications and research groups that are dealing with them.

2.2 Orthogonal and Oblique Cutting

The chip flow in all wedged-tool machining processes can be described, in theory, in a common way by two different cutting schemes termed orthogonal cutting and oblique cutting, depicted in Figs. 2.1 and 2.2 respectively. In orthogonal cutting the cutting edge of the tool is perpendicular to the direction of relative workpiece-cutting tool motion and also to the side face of the workpiece. From the relative movement of workpiece and cutting tool, a layer of material in the form of chip is removed. In order to continue removing material at a second stage, the tool is taken back to its starting position and fed downwards by the amount f , the feed of the process. Perpendicular to f , d is the depth of cut, which is smaller than or equal to the width of the tool edge. The surface along which the chip flows is the rake face of the tool. The angle between the rake face and a line perpendicular to the machined surface is called rake angle γ . The face of the tool that is near the machined surface of the workpiece is the flank face. The angle between the flank face of the tool and the workpiece is called clearance angle α . The angle between the rake face and the flank face is the wedge angle β . The sum of the three angles is always equal to 90° , thus:

$$\alpha + \beta + \gamma = 90^\circ \quad (2.1)$$

In Fig. 2.1 a positive rake angle is shown; in the same figure the direction for a positive or a negative rake angle is shown. For negative rake angles, the tools possess a wider wedge angle. As pointed out in Sect. 1.2.1, a positive rake angle is used for ductile materials since a “weaker” tool, with smaller wedge angle, will suffice to perform the cutting operation. For high-strength materials, rake angle is chosen to be negative, thereby increasing the wedge angle and creating a stronger cutting edge. However, stronger cutting edge has the disadvantage of requiring greater power consumption and needing a robust tool-workpiece set-up to compensate for the vibrations. The flank face of the tool does not participate in chip removal; it ensures that the tool does not rub on the newly machined surface and affects its quality. However, the clearance angle affects the cutting tool wear rate. If the tool’s clearance is too large it will weaken the wedge angle of the tool, whereas if too small, it will tend to rub on the machined surface.

Orthogonal cutting represents a two-dimensional mechanical problem with no side curling of the chip considered. It represents only a small fragment of machining processes, i.e. planning or end turning of a thin-walled tube. However, it is widely used in theoretical and experimental work due to its simplicity. Because of its 2D

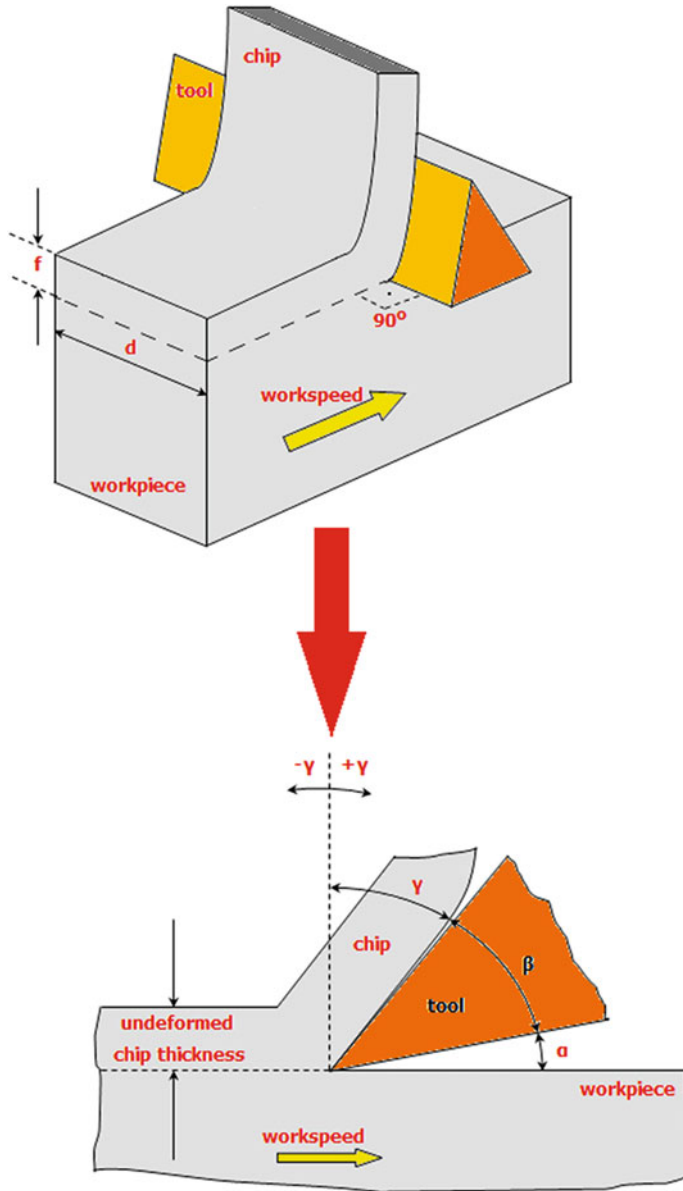

Fig. 2.1 Orthogonal cutting

nature many independent variables are eliminated, e.g. two cutting forces are only identified to orthogonal cutting problems. On the other hand, oblique cutting, where the cutting tool is inclined by angle λ , as it can be seen in Fig. 2.2, corresponds to a three-dimensional problem with more realistic chip flow representation but more

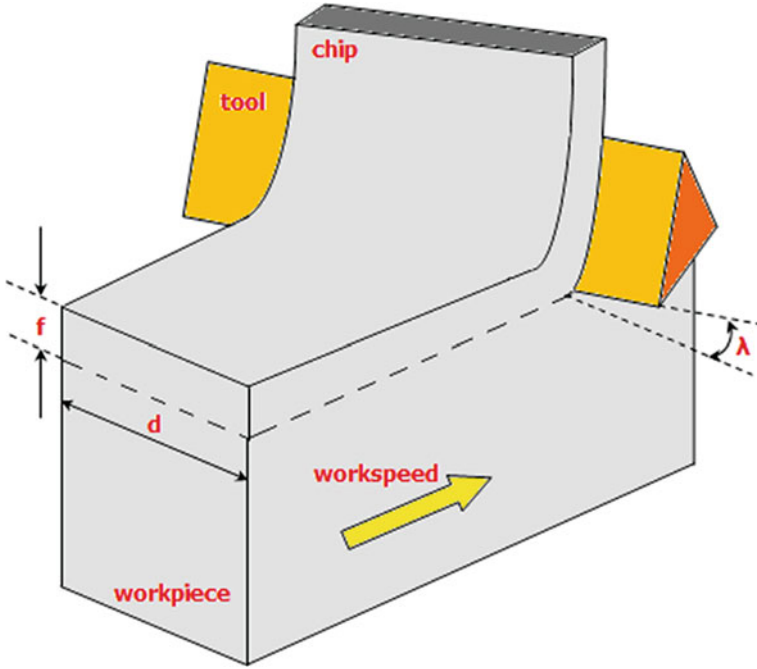

Fig. 2.2 Oblique cutting

complex analysis, i.e. three force components are present and chip curling is accounted for.

In oblique cutting that is a more general case than orthogonal, there are three mutually perpendicular cutting force components. If a coordinate system based on the directions of work speed and feed is adopted, the cutting force, the feed force and the back force are considered. The cutting force is usually the largest and back force the smallest component. For orthogonal cutting, the third force component is ignored, so the force system lies in a single plain, normal to the cutting edge of the tool. The measurement and/or the theoretical calculation of the two cutting force components as well as their resultant force have been the subject of numerous researches in the past. The importance of the knowledge of cutting forces, prior to machining if possible, is important because through these the power requirements of the machine tool, the cutting tool properties and workpiece quality are estimated. For example, if feed force is high and the tool holder is not stiff enough, the cutting edge will be pushed away from the workpiece surface, causing lack of dimensional accuracy. Furthermore, determination of cutting forces can easily lead to the calculation of other parameters, e.g. stresses.

There are two deformation areas distinguished in machining, namely the primary and the secondary deformation zones, see Fig. 2.3; the deformation zones thickness, chip thickness and shear angle are not depicted in any scale in this figure, only the locations are roughly indicated. The primary deformation zone is included in the

plane and the workpiece surface. Although this single shear plane model is criticized, it is usually referred in machining handbooks due to its simplicity and it is the basis for calculating several process parameters. In any case, it is imperative to estimate shear angle and friction parameters in order to calculate cutting forces, as explained above. In the next section, an overview of the theoretical approach of machining, cutting mechanics, advances in cutting mechanics and analytical models will be discussed, before moving on to FEM analysis, since all these topics are closely connected.

2.3 Cutting Mechanics and Analytical Modeling

The history of research pertaining to metal cutting is well documented by Finnie [6] who pinpoints the work of Cocquilhat [7] in 1851 as the first research in the area of measuring the work required to remove a given material volume by drilling. However, the first work on chip formation by Time [8] in 1870 presented the results obtained when observing cutting. In this publication it was argued that the chip is created by shearing ahead of the tool. Astakhov claims that this is one of the first publication that a shear plane theory is suggested [9], probably the first being the one by Usachev in 1883 [10]. It is also shown that there is no contradiction between Time and Tresca [11]; Tresca argued that the chip in metal cutting is produced by compression ahead of the tool. Zvorykin [12] was the first to provide physical explanation for this model; his work resulted to an equation predicting the shear angle. In 1881, Mallock [13] also identified the shearing mechanism in chip formation and emphasized the importance of friction in the tool-chip interface. However, it was the work of Ernst and Merchant [14] in 1941 that made the shear plane model popular; most of the fundamental works on metal cutting mechanics reference this paper and many analytical models of orthogonal cutting still use the relations derived from this work. In the following paragraphs some key points of analytical modeling and advances in mechanics of cutting will be discussed.

Analytical models, only briefly described, are considered the predecessors of numerical models. This is by no way meant to say that numerical models substituted analytical modeling, since a lot of researchers still are working on this subject and the value of these models is paramount. It is meant to say that they have the same origins and form the basis on which FEM models and simulations are made. In another paragraph it will be discussed what the benefits, and some drawbacks as well, are from choosing numerical modeling over analytical. As it can be concluded analytical models are quite controversial and up to date there is no model universally accepted or employed. The subject cannot be portrayed in its full length within this book. However, many excellent books on mechanics of machining can be found and it is the author's opinion that they should be considered by the prospective modeler before moving on to numerical or any other kind of machining modeling [5, 9, 15–18]. These books include theory of

plasticity, slip-line theory, shear zone models and usually chapters on numerical modeling as well, among other subjects.

2.3.1 Lower and Upper Bound Solutions

Most of the analytical modeling works aim at producing equations that can determine cutting forces, without any experimental work; that is useful since other parameters can be derived by cutting forces and analysis in tool wear, surface integrity and workpiece quality can be carried out. The problem involved in the determination of the cutting forces, when the cutting conditions are known, ends up in determining a suitable relationship between the shear angle, the rake angle and the friction coefficient. Several methods have been employed that either overestimate or underestimate the results; the real value of the cutting forces probably lies between these lower and upper bounds.

Lower bound solutions employ the principle of maximum work, i.e. the deformation caused by the applied stresses results to maximum dissipation of energy. The system tends to reach the state of minimum energy compatible with the equilibrium and yield conditions. Any other statically compatible system will produce work that is either equal or less than that of the actual system.

In the upper bound solutions the strain increments of a fully plastic body rather than the stress equilibrium is considered. The principle of maximum work is employed in this case from the point of view of strain. The material is incompressible, thus the plastic volume remains constant. An element of this system deforms so that it exhibits maximum resistance. If the stresses are deduced from deformations imposed by the kinematic conditions, the estimation of their values will be equal or greater than the ones actually occurring.

2.3.2 Shear Plane Models

Shear plane models are closely connected to the theory of Ernst and Merchant, as mentioned above. This shear model was based on the so-called card model of Piispanen [19, 20]. The chip is formed by shear along a single plane inclined at an angle ϕ . The chip is straight and has infinite contact length with the tool. The shear stress along the shear plane is equal to the material flow stress in shear.

The chip is assumed to be a rigid body in equilibrium. The equilibrium refers to the forces on the chip-tool interface and across the shear plane. In Fig. 2.4 the Merchant's circle force diagram is given. All forces are shown acting at the tool tip.

The resultant force F is resolved in components F_N and F_F that are normal to the tool face the former and along the tool face the latter. It is also resolved to F_{SN} and F_S that are normal to and along the shear plane respectively. Finally, it can also be resolved into components F_c , the cutting force, and F_t the feed or thrust force. Furthermore, the rake angle γ , the shear angle ϕ and the mean angle of friction

Thus from Eqs. 2.3 and 2.4 it is:

$$F = \frac{\tau_s A_c}{\sin \phi} \cdot \frac{1}{\cos(\phi + \rho - \gamma)} \quad (2.5)$$

Geometrically it is deduced that:

$$F_c = F \cos(\rho - \gamma) \quad (2.6)$$

Combining Eqs. 2.5 and 2.6 it may be concluded that:

$$F_c = \frac{\tau_s A_c}{\sin \phi} \cdot \frac{\cos(\rho - \gamma)}{\cos(\phi + \rho - \gamma)} \quad (2.7)$$

If the last equation is differentiated with respect to ϕ and equated to zero, it is possible to calculate a shear angle for which the cutting force is minimum. The equation is:

$$2\phi + \rho - \gamma = \pi/2 \quad (2.8)$$

This equation agreed poorly with experimental results of metal machining. Merchant attempted an alternative solution [21]. When Eq. 2.7 was differentiated it was assumed that A_c , γ and τ_s were independent of ϕ . In the new theory, deformation and friction are reflected through a change of the force acting in the direction perpendicular to the plane of shear, thus the normal stress σ_s of the shear plane affects the shear stress τ_s . In the modified analysis a new relation is included:

$$\tau_s = \tau_o + k\sigma_s \quad (2.9)$$

This relation is known as the Bridgman relation and k is the slope of the $\tau - \sigma$ relation; the shear stress increases linearly with an increase in normal strength and the lines intersects the shear stress axis at τ_o . With this revised theory the new result for shear angle is:

$$2\phi + \rho - \gamma = C \quad (2.10)$$

C is a constant that depends on the workpiece material.

2.3.3 Slip-Line Field Models

Stress analysis in a plane strain loaded material indicates that at any point there are two orthogonal directions that the shear stresses are reaching a maximum, but these directions can vary from point to point. A line, which generally speaking is curved, tangential along its length to the maximum shear stress is called a slip-line; a complete set of slip-lines in a plastic region forms a slip-line field. The slip-line field theory must follow rules that allow the construction of a slip-line field for a particular case. First of all, the boundary between a part of a material that is plastically loaded and another that has not yielded is a slip-line. In machining, the

Fig. 2.5 Lee and Shaffer's slip-line field theory for orthogonal cutting

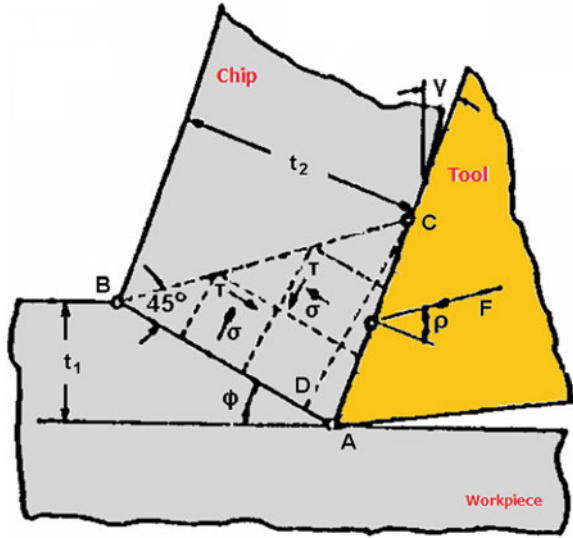

borders of the primary deformation zone with the workpiece on the one side and the chip on the other are slip-lines. Similarly, a slip-line is the border between the secondary deformation zone and the chip. Another rule is that slip-lines must intersect free surfaces at 45° angle.

Lee and Shaffer's work was the first contribution of the slip-line field models of chip formation [22]. It was the result of applying simplified plasticity analysis to metal cutting, more specifically to orthogonal cutting with continuous chip. It was assumed that in this plane strain conditions, the workpiece material is rigid perfectly plastic, i.e. the elastic strain is neglected during deformation and once the yielding point is exceeded deformation takes place at constant stress for varying strains, strain rates and temperatures. The constructed slip-line field is shown in Fig. 2.5.

In this lower bound solution all deformations take place in a stress field bounded by rigid bodies; this stress field transmits the cutting forces from the shear plane to the chip resulting in the triangular plastic zone ABC. In this region no deformation occurs but the material is stressed to its yield point, so that the maximum shear stress is the shear stress on the shear plane. The two directions of the maximum shear stress are indicated by the slip-lines. The shear plane AB is the one set of slip-lines because the maximum shear stress must occur along the shear plane. Furthermore, BC can be regarded a free surface since no forces act on the chip after BC, stresses cannot be transmitted from there. Thus, according to the second rule mentioned above, ABC is equal to $\pi/4$. Assuming that stresses act uniformly at the chip-tool interface, normal stresses will meet the boundary at angles ρ and $\rho + \pi/2$. Maximum shear stresses are $\pi/4$ to the direction of normal stresses and thus ACB is $(\pi/4) - \rho$. The shear angle can be calculated by equation:

$$\phi + \rho - \gamma = \pi/4 \quad (2.11)$$

It is evident that when the mean angle of friction between chip and tool is $\pi/4$ and the rake angle is zero, shear plane angle is also zero, which is not possible. Lee and Shaffer proposed a solution for this case of high friction and low rake angle, assuming built-up edge formation.

The slip-line theory was also used by other researchers who suggested curved AB and CD boundaries [23, 24]. These models reveal the non-uniqueness of machining processes; different chip shapes and thicknesses result from the same specified conditions. The non-uniqueness of the possible solutions is a significant limitation, resulting mainly by the rigid plastic workpiece material assumption.

At this point it would be interesting to make a note on the work of Zorev in relation to the slip-line field theory [5]. Zorev proposed an approximate form of the shear lines in the plastic zone as it can be seen in Fig. 2.6 on top. This is a qualitative model for which no solution is provided. However, a simplified form was proposed as shown in the same figure; in this simplified model the curved shear lines are replaced by straight ones and it is assumed that no shearing occurs along the shear lines adjacent to the tool rake face. By using geometrical relationships a generalized solution is derived as:

$$2\phi_{sp} + \rho - \gamma \approx (\pi/2) - \psi_{sp} \quad (2.12)$$

In this equation the ϕ_{sp} , the specific shear angle is introduced and ψ_{sp} is the angle of inclination of the tangent to the outer boundary of the plastic zone. The interesting about this solution is that if various values of ψ_{sp} are substituted, the shear angle relations by other researchers are derived, i.e. for ψ_{sp} equal to zero, representing the single shear plane model, the Ernst and Merchant solution is obtained, for $\psi_{sp} = C_1$ and $C = (\pi/2) - C_1$ the modified Merchant solution is obtained and for $\psi_{sp} = \rho - \gamma$ the Lee and Shaffer solution is derived.

2.3.4 Shear Zone Models

The next step in analytical modeling was to enhance some features that were neglected or simplified in previous models but play an important role in metal cutting. Most shear plane models assume that shear stress on the shear plane is uniform, no strain hardening is considered and that friction along the cutting tool-chip interface is characterized by a constant friction coefficient; this last assumption is in contradiction with experimental data. If it is assumed that deformation takes place in a narrow band centered on the shear plane, more general material assumptions can be used. The effects of yield stress varying with strain and sometimes with strain rate and temperature were considered and simplification of the equilibrium and flow was achieved. Pioneering work in this area is associated with the work of Oxley. Based on experimental data, where the plastic flow patterns are observed, it is assumed that the shear zone thickness is about one tenth of the shear zone length. Then strain rate and strain at every point in the primary deformation zone can be calculated; strain rates are derived from

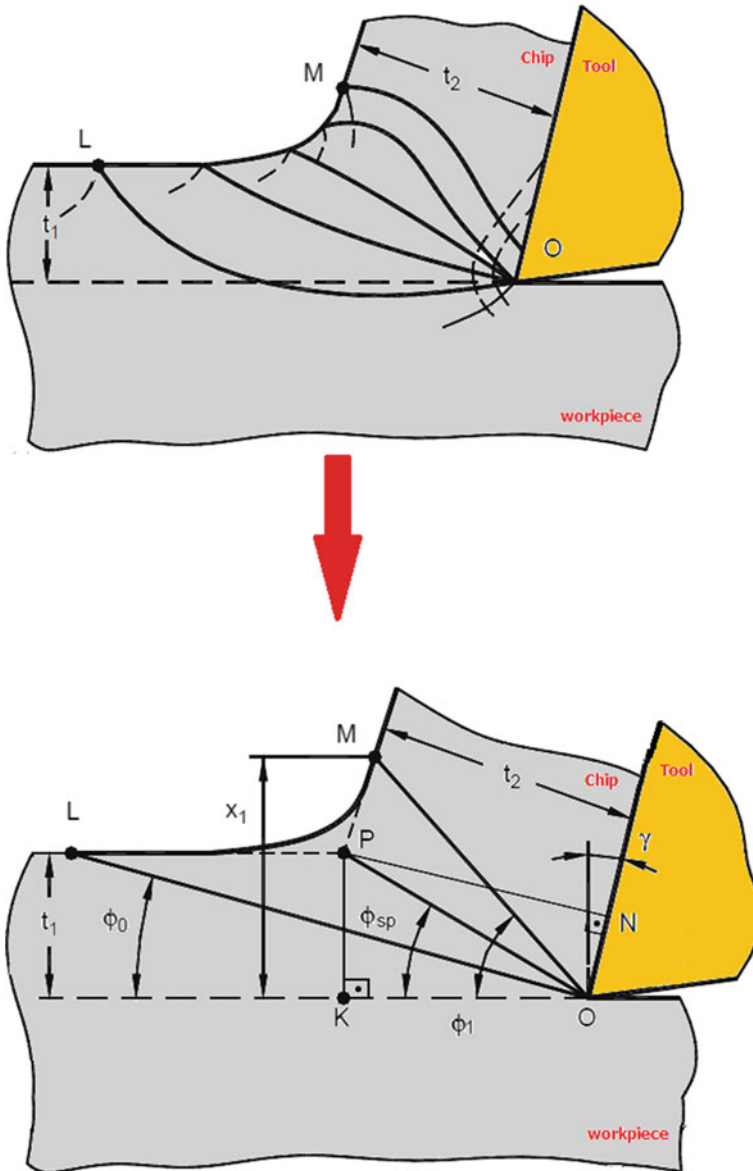

Fig. 2.6 Zorev's qualitative model on *top* and simplified model *below*

variations in the velocity with respect to the position and strains are calculated by integrating strain rates with respect to time along the streamlines of the flow. Similar assumptions are used to compute strain rates and strains in the secondary deformation zone.

Table 2.1 Shear angle formulas

Model	Formula	Year
Ernst–Merchant	$\phi = \frac{\pi}{4} - \frac{1}{2}(\rho - \gamma)$	1941
Merchant	$\phi = \frac{\zeta}{2} - \frac{1}{2}(\rho - \gamma)$	1945
Stabler	$\phi = \frac{\pi}{4} - \rho + \frac{\gamma}{2}$	1951
Lee–Shaffer	$\phi = \frac{\pi}{4} - (\rho - \gamma)$	1951
Hucks	$\phi = \frac{\pi}{4} - \frac{\alpha \tan(2\mu)}{2} + \gamma$	1951
Shaw et al.	$\phi = \frac{\pi}{4} - (\rho - \gamma) \pm \eta$	1953
Sata	$\phi = \frac{\pi}{4} - \gamma \pm \frac{\gamma - 15^\circ}{2}$	1954
Weisz	$\phi = 54.7^\circ - (\rho - \gamma)$	1957
Kronenberg	$\phi = a \cot \left[\frac{e^{\mu \left(\frac{\pi}{4} - \gamma \right)} - \sin \gamma}{\cos \gamma} \right]$	1957
Colding	$\phi = a \tan \left[-\frac{2 \left(\frac{F}{H} + 2 \right)}{\left(\frac{F}{H} + 1 \right)} \cot(2\Omega) - (\rho - \gamma) \right]$	1958
Oxley	$\phi = a \tan \left[1 + \frac{\pi}{2} - 2\phi + \frac{\cos 2(\phi - \gamma)}{\tan \rho} - \sin 2(\phi - \gamma) \right] - (\rho - \gamma)$	1961
Sata–Yoshikawa	$\phi = a \cot \left[\cot \theta + \frac{\cos \theta}{\sin(\theta + \gamma)} kL \right]$	1963
Das–Tobias	$D = \frac{\cos(\rho - \gamma)}{\cos(\rho - \gamma + \phi)}$	1964

The shear zone models are an obvious improvement over the preceding models. Many additions to the first model proposed by Oxley have been reported. A full account of these developments would be out of the scope of this work; a detailed description of Oxley's works is given in [17].

2.3.5 Discussion on Analytical Modeling of Machining

The analysis presented here is not at all a complete one; with more than 50 shear angle solutions identified in the relevant literature as it is reported in [3] this would be impossible within this book. However, an outline of the most important models and the development over the years is presented. Furthermore, in Table 2.1 some shear angle formulas are gathered. In the following lines some drawbacks in the analytical modeling procedure are discussed.

The single shear plane model has been criticized over the years and experimental data do not correlate with the theory results. Astakhov [25] summarized the major inherent drawbacks of the single shear plane model as being the infinite strain rate, the unrealistic high shear strain that is in contradiction with material testing results, the rigid perfectly plastic workpiece material assumption, the improper accounting for the resistance of the processed workpiece material, the perfectly sharp cutting edge of the tool and the fact that there is no contact on the tool flank surface that are not realistic for common practice and the inapplicability of the model in brittle material machining. Furthermore, for the Ernst and Merchant theory, drawbacks include the incorrect velocity and force diagrams presented and the assumption of

constant friction coefficient. However, this model is still in use by researchers due to its simplicity.

Slip-line solutions like the ones presented in Sect. 2.3.3 also have poor correlation with experimental results and no strain hardening is considered. Furthermore, the non-uniqueness of the models raises criticism on the results. Finally, Zorev's general model is based on geometrical considerations and no principle of mechanics of materials or physical laws are used. It is argued that all solutions related to this model, including Ernst and Merchant and Lee and Shaffer theory have little to do with physics and the mechanics of metal cutting [25].

The analyses already presented pertained only to orthogonal cutting with continuous chip. However, the shear plane model has been extended to three dimensions [26] and the slip-line model has been proposed for oblique cutting [27]. A three-dimensional analysis similar to the work of Oxley has been presented by Usui [28–30], which includes secondary cutting edge and nose radius effects; the results apply to turning, milling and groove cutting. However, both Oxley's and Usui's models are quite complex and for their application stress and strain data at the strain rates and temperatures encountered in metal machining are needed. The lack of these data is a significant drawback. These are the reasons that these models, although more complete than all the others since they include temperature effects and can be used in tool wear and segmented chip formation modeling and are in agreement with experimental data, are not widely used outside the research groups that they developed them. Nevertheless, Usui's tool wear estimation algorithm is integrated into finite element models for the prediction of tool wear; the commercial FEM software Third Wave AdvantEdge has the option of using this algorithm in the analyses it can perform.

Finally, another form of modeling for cutting force models will be briefly discussed here, namely Mechanistic modeling; a review can be found in [31]. This kind of modeling is not purely analytical because it is based on metal cutting mechanics but also depends on empirical cutting data; it is a combination of analytical and experimental modeling techniques. Such an approach avoids the complications of incorporating parameters such as shear angle and friction angle, by using experimental force data and it is suitable for use in oblique cutting and various cutting processes.

References

1. Grzesik W (2008) Advanced machining processes of metallic materials. Theory modelling and applications. Elsevier, Oxford
2. Shaw MC (1984) Metal cutting principles. Oxford University Press, Oxford
3. van Luttervelt CA, Childs THC, Jawahir IS, Klocke F, Venuvinod PK (1998) Present situation and future trends in modeling of machining operations. In: Progress report of the CIRP working group "modeling and machining operations". Annals of the CIRP, vol 47/2, pp. 587–626
4. Stephenson DA, Agapiou JS (2006) Metal cutting theory and practice, 2nd edn. CRC Press, FL

5. Zorev NN (1966) Metal cutting mechanics. Pergamon Press, Oxford
6. Finnie I (1956) Review of the metal cutting analyses of the past hundred years. *Mech Eng* 78(8):715–721
7. Coquilhat M (1851) Expériences sur la Resistance Utile Produite dans le Forage. *Annales Travaux Publics en Belgique* 10:199–215
8. Time I (1870) Resistance of metals and wood to cutting (in Russian). Dermacow Press House, St. Petersburg
9. Astakhov VP (1999) Metal cutting mechanics. CRC Press, FL
10. Usachev YG (1915) Phenomena occurring during the cutting of metals—review of the studies completed (in Russian). *Izv. Petrogradskogo Politechnicheskogo Inst.*, XXIII(1)
11. Tresca H (1873) Mémoires sur le Rabotage des Métaux. *Bulletin de la Société d'Encouragement pour l' Industrie Nationale*, 585–607
12. Zvorykin KA (1896) On the force and energy necessary to separate the chip from the workpiece (in Russian). *Vetnik Promyslennostie*, 123
13. Mallock A (1881–1882) The action of cutting tools. *Proc Roy Soc Lond* 33:127–139
14. Ernst H, Merchant ME (1941) Chip formation, friction and high quality machined surfaces. Surface treatment of metals. *Am Soc Met* 29:299–378
15. Childs THC, Maekawa K, Obikawa T, Yamane Y (2000) Metal machining: theory and applications. Elsevier, MA
16. Bhattacharyya A (1994) Metal cutting theory and practice. New Central Book Agency Ltd, Kolkata
17. Oxley PLB (1989) The mechanics of machining: an analytical approach to assessing machinability. Ellis Horwood, Chichester
18. Dixit PM, Dixit US (2008) Modeling of metal forming and machining processes by finite element and soft computing methods. Springer, London
19. Piispanen V (1937) Lastunmuodostumisen Teoriaa. *Teknillinen Aikakauslehti* 27:315–322
20. Piispanen V (1948) Theory of formation of metal chips. *J Appl Phys* 19:876–881
21. Merchant ME (1945) Mechanics of the metal cutting process II. Plasticity conditions in orthogonal cutting. *J Appl Phys* 16(6):318–324
22. Lee EH, Shaffer BW (1951) The theory of plasticity applied to a problem of machining. *Trans ASME—J Appl Mech* 18:405–413
23. Kudo H (1965) Some new slip-line solutions for two-dimensional steady-state machining. *Int J Mech Sci* 7:43–55
24. Dewhurst P (1978) On the non-uniqueness of the machining process. *Proc Roy Soc Lond* A360:587–610
25. Astakhov VP (2005) On the inadequacy of the single-shear plane model of chip formation. *Int J Mech Sci* 47:1649–1672
26. Shaw MC, Cook NH, Smith PA (1952) The mechanics of three-dimensional cutting operations. *Trans ASME* 74:1055–1064
27. Morcos WA (1980) A slip line field solution of the free continuous cutting problem in conditions of light friction at chip-tool interface. *Trans ASME—J Eng Ind* 102:310–314
28. Usui E, Hirota A, Masuko M (1978) Analytical prediction of three dimensional cutting process. Part 1. Basic cutting model and energy approach. *Trans ASME—J Eng Ind* 100:222–228
29. Usui E, Hirota A (1978) Analytical prediction of three dimensional cutting process. Part 2. Chip formation and cutting force with conventional single-point tool. *Trans ASME—J Eng Ind* 100:229–235
30. Usui E, Shirakashi T, Kitagawa T (1978) Analytical prediction of three dimensional cutting process. Part 3. Cutting temperature and crater wear of carbide tool. *Trans ASME—J Eng Ind* 100:236–243
31. Ehmann KF, Kapoor SG, DeVor RE, Lazoglu I (1997) Machining process modeling: a review. *Trans ASME—J Manuf Sci Eng* 119:655–663