

[A Practical Design of Lumped, Semi-lumped & Microwave Cavity Filters](#)

Bearbeitet von
Dhanasekharan Natarajan

1. Auflage 2012. Buch. xii, 148 S. Hardcover
ISBN 978 3 642 32860 2
Format (B x L): 15,5 x 23,5 cm
Gewicht: 409 g

[Weitere Fachgebiete > Technik > Elektronik > Mikrowellentechnik](#)

Zu [Inhaltsverzeichnis](#)

schnell und portofrei erhältlich bei

DIE FACHBUCHHANDLUNG

Die Online-Fachbuchhandlung [beck-shop.de](#) ist spezialisiert auf Fachbücher, insbesondere Recht, Steuern und Wirtschaft. Im Sortiment finden Sie alle Medien (Bücher, Zeitschriften, CDs, eBooks, etc.) aller Verlage. Ergänzt wird das Programm durch Services wie Neuerscheinungsdienst oder Zusammenstellungen von Büchern zu Sonderpreisen. Der Shop führt mehr als 8 Millionen Produkte.

Chapter 2

RF Filter Terms

Abstract Impedance, Characteristic impedance, RF transmission line and VSWR are fundamental terms not only for the design of RF filters but also for all RF components and circuits. The terms are explained in detail with simple examples for physical understanding. Impedance is explained for a discrete reactive element circuit and for a single load resistor introducing the concept of distributed reactive elements. The construction and characteristics of coaxial, microstrip and stripline transmission lines are explained. VSWR is explained graphically with numerical examples for transmission line with open-circuited load, short-circuited load, matched load, infinitely long coaxial cable and partially matched load after explaining its practical significance.

2.1 Introduction

RF filters are designed as per customer requirements. The requirements vary among the four basic types (low pass, high pass, band pass and band stop) of filters. However, all the four types of filters have a few requirements in common. RF filters are designed for the standardised input/output characteristic impedance, 50 Ω . RF transmission lines are used in the design of microwave filters. Input and output VSWR of filters are measured to verify compliance to the specified characteristic impedance and to ensure minimum insertion loss. Impedance, Characteristic impedance, RF transmission lines and VSWR are fundamental terms not only for the design of RF filters but also for all RF components and circuits. Hence, the terms are explained in detail with examples. The other filter terms such as Insertion loss, Band width and Rejection represent the characteristics of filters and they are explained in [Chap. 3](#).

Fig. 2.1 A discrete reactance circuit

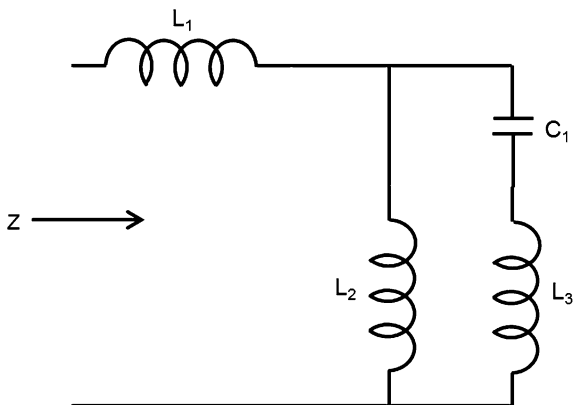

2.2 Impedance

2.2.1 Definition

Resistance (R) is defined as the measure of the opposition to direct current (DC) or alternating current (AC) assuming that the resistance is pure in the sense that it does not have inductive or capacitive reactance. It is expressed in ohms.

Impedance (Z) is analogous to resistance and is defined as the measure of the opposition to the flow of alternating current. Resistance (R) and reactance (X) are part of impedance. Reactance may be due to inductance or capacitance or both. It is expressed in ohms.

$$Z = \sqrt{R^2 + X^2}$$

If $X = 0$, the impedance is said to be resistive. At lower frequencies, impedance is relevant for a discrete circuit having resistors, inductors and capacitors connected in series/parallel configuration. A 4-element discrete circuit with capacitors and inductors is shown in Fig. 2.1. The impedance of the circuit is calculated using appropriate expressions for the series/parallel configuration.

2.2.2 Load Resistor at Radio Frequency

At VHF and microwave frequencies, impedance becomes relevant even for a single element circuit having one resistor. Figure 2.2 shows a single element load resistance (R_L) circuit with a VHF signal source having source impedance, Z_S . Though inductors and capacitors are not physically connected in the circuit, the load resistance is load impedance to the VHF source due to the effect of distributed inductance and capacitance present in the load resistor, R_L . The distributed elements could be understood by examining the construction of the load resistor.

Fig. 2.2 VHF circuit with load resistance

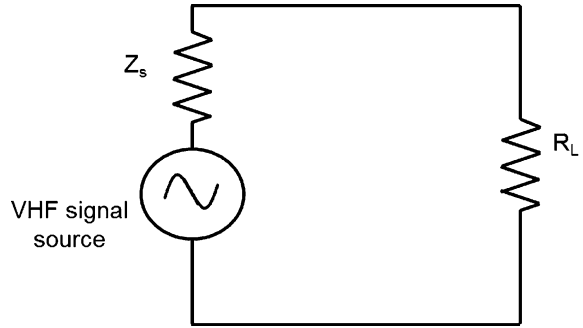
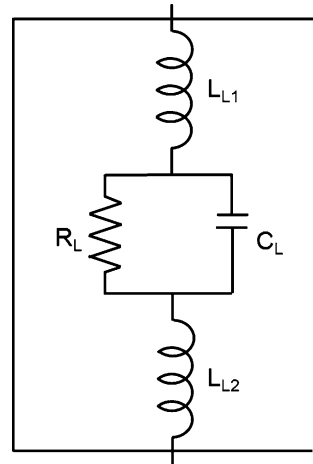

Fig. 2.3 RF equivalent circuit of the load, R_L



For better understanding, assume that the load resistance, R_L , is a resistor with leads. Leaded resistor has a ceramic rod over which the resistive element is vacuum deposited. The deposited resistive element is spirally cut to adjust its resistance value within tolerance. Metallic end caps are attached to the ceramic rod and they make electrical contact with the resistive element. The leads (terminations) are then attached to the end caps. Finally, a suitable insulating epoxy is applied over the resistive element for environmental protection.

Examining the construction of the load resistor, the terminations function as inductors, L_{L1} and L_{L2} . The protective epoxy coating acts as a dielectric and hence a capacitor, C_L , is present between the end caps. L_{L1} and L_{L2} are distributed inductances and C_L is distributed capacitance as they are spread (distributed) over the leaded load resistor. Other distributed reactive elements in the load resistor are negligible. The RF equivalent circuit of the load resistor with its resistive and distributed reactive elements is shown in Fig. 2.3. Hence, the load resistance, R_L , with its distributed reactive elements becomes load impedance, Z_L at VHF and microwave frequencies.

2.2.3 Standard Terminations

For the performance verification of RF components such as filters, the input of the component is connected to RF source and the output is terminated with resistive load impedance. Load impedances are standardised to 75 and 50 Ω . Standard termination is a commercial terminology for the standardised loads. The terminations are specially designed coaxial film resistors minimising distributed capacitance and inductance. They are available in BNC, TNC, N, SMA and other connector series. The terminations are used for the initial set up calibration of RF test equipments. The frequency of application is generally limited to 1 GHz for 75 Ω terminations whereas 50 Ω terminations are used up to microwave frequencies.

The concept of minimising distributed inductance and capacitance is used to design resistive termination at microwave frequencies by cancelling inductive reactance with capacitive reactance at that frequency using reactive matching networks [1].

2.3 RF Transmission Line

2.3.1 Definition

A transmission line is a pair of electrical conductors that transfer power from a source to a load. One of the two conductors functions as forward path from the source to the load and the other functions as return path from the load to the source thus closing the circuit for current flow. A transmission line with open type of conductors is shown in Fig. 2.4.

Transmission lines with open type conductors function satisfactorily for transferring power from source to load at DC and at power frequency (50/60 Hz)

Fig. 2.4 Open type transmission lines

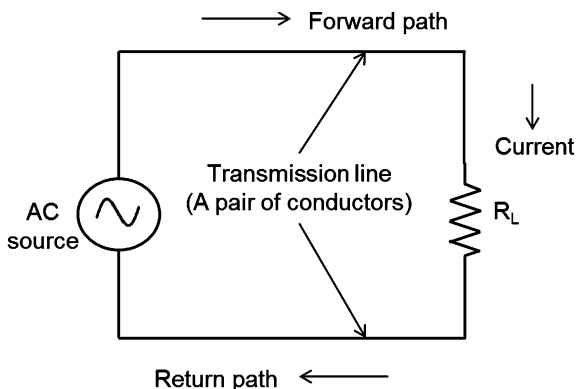

or up to 100 kHz with acceptable degradation. However, the open transmission lines are not acceptable at radio frequency as it will result in the loss of RF signals when transferring power from source to load. RF signals are electromagnetic waves and they propagate through a dielectric medium including free space and vacuum. A specially designed structure having a dielectric medium contained by electrically conducting walls is required for the propagation of electromagnetic waves to minimise the loss of RF signals. The specially designed structure is RF transmission line. Many designs of transmission lines are available considering frequency, loss and other interconnection requirements of applications.

2.3.2 Types of Transmission Lines

The RF transmission line structures that find wide applications are:

1. Coaxial transmission lines
2. Microstrip transmission lines
3. Stripline transmission lines

Feeder cables to antennas and interconnection cables between RF sub-systems are some of the applications of coaxial cables. Microstrip and stripline lines find applications in the design of filters and other RF components. The construction and characteristics of coaxial and microstrip/stripline transmission lines are explained. Waveguides are special form of transmission lines and they are used at microwave frequencies.

2.4 Coaxial Transmission Lines

2.4.1 Construction and Characteristics

Coaxial cables are the most commonly used form of coaxial transmission lines. The cables are flexible and they are available off-the-shelf with varied constructions. In a coaxial cable, the inner and outer conductors share the same axis i.e. they are designed to be coaxial to each other. The cross section of a coaxial cable in general form is shown in Fig. 2.5.

A dielectric material is placed between the inner and outer conductors to maintain the coaxial structure throughout its length. The dielectric material is polyethylene or PTFE in coaxial cables. The electromagnetic waves of RF signal are contained between inner and outer conductors and they travel in the dielectric medium. The constructional features of coaxial cables decide the attenuation (loss), maximum frequency of application and operating ambient temperature.

Fig. 2.5 Cross section of a coaxial cable

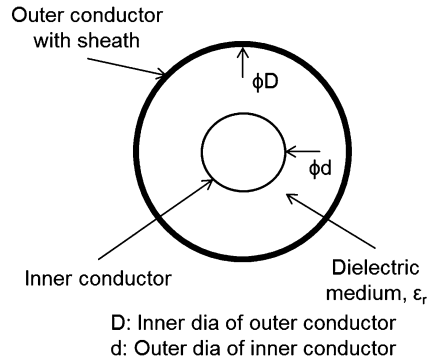

The dielectric material of coaxial cables contributes significantly for the loss of the cables. Air bubbles are injected during the manufacture of polyethylene or PTFE dielectric material and the air-foamed dielectric cables have lower loss. Selecting coaxial cables with higher diameter or with silver plated inner/outer conductors reduces the loss of the cables further. Coaxial cable is available with outer conductor braided with many strands of copper wires or with seamless copper tube. Coaxial cables with seamless copper tube outer conductor and PTFE dielectric are semi-rigid cables and they are suitable for applications up to 20 GHz. The maximum operating ambient temperature is 85 °C for cables with polyethylene dielectric and is 180 °C for PTFE dielectric cables.

TEM (Transverse Electro-Magnetic) mode is the dominant mode of propagation in RF coaxial cables. The propagation modes of transmission is briefly explained in Appendix-1. TEM mode in coaxial cables changes to higher order modes at a frequency called cut-off frequency, resulting in very high attenuation and hence the operating frequency of coaxial cables should be lower than the cut-off frequency. The expression published by leading international cable manufacturers is useful to estimate the cut-off frequency, f_c , of a coaxial cable.

$$f_c(\text{GHz}) \approx 191 / [(D + d) (\sqrt{\epsilon_r})]$$

D Inner diameter of outer conductor in mm

d Outer diameter of inner conductor in mm

ϵ_r is the relative dielectric constant of the medium between the conductors

2.4.2 Standard Coaxial Air Lines

RF coaxial transmission lines with air as dielectric are Standard air lines. Standard air line has rigid silver plated inner and outer conductors which are connected to precision 7 or 3.5 mm coaxial connectors on both sides. The centre conductor of standard air line is mechanically supported by the centre conductors of the end

coaxial connectors. Standard air lines are characterised by the lowest loss per meter and VSWR. They are used as standards for impedance measurements.

2.5 Microstrip/Stripline Transmission Lines

Microstrip or stripline transmission line patterns are designed and printed on PTFE copper clad laminate. The laminate is a sheet of PTFE insulating material (substrate) bonded with copper sheet on both sides. Transmission line patterns printed on the laminate by special chemical etching processes. The unwanted copper is etched out on both sides of substrate by the chemical processes. Copper conductor (transmission line) width, thickness of substrate and the dielectric constant of the substrate decide the ‘characteristic impedance’ of microstrip or stripline transmission lines. Characteristic impedance and the applications of basic microstrip and stripline configurations are explained in Chap. 4. Advanced filler materials are added to the PTFE substrate for improving the stability and Q-factor of PTFE copper clad laminate. For HF and VHF applications, glass epoxy copper clad sheets is also used for designing RF components in microstrip and stripline configurations.

2.6 Characteristic Impedance

Characteristic impedance is explained for coaxial transmission line. The cross section of a coaxial cable shown in Fig. 2.5 is referred for explaining the characteristic impedance of a coaxial transmission line. Assume that the length of coaxial cable is infinite or long enough to act as load impedance. The inner and outer conductors have series distributed inductance. Distributed capacitance is present across the conductors throughout the length of the coaxial cable. The cable has also series DC resistance and shunt conductance but their contributions for the input impedance of the cable are considered negligible compared to the reactance at high frequencies. The input impedance of the cable is given by the expression, $\sqrt{(L/C)}$, where L is the distributed inductance and C is the distributed capacitance per unit length of the coaxial cable [2]. The values of L and C are related to the parameters, D, d, and ϵ_r , shown in Fig. 2.5. In other words, D, d and ϵ_r distinctly defines or characterises the input impedance of a coaxial cable. Hence, the characteristic impedance of a coaxial transmission line is defined as the input impedance of the line and is expressed in terms of D, d and ϵ_r [3]. Its unit is ohms and the symbol is Z_0 .

$$\text{Characteristic impedance, } Z_0 = \frac{60 \ln(D/d)}{\sqrt{\epsilon_r}} \text{ ohms}$$

Characteristic impedance of a coaxial cable is measured using Vector Network Analyser with Time Domain Reflectometer (TDR) software. TDR equipment with Standard air line is also used for measuring the impedance. As the characteristic impedance of a coaxial cable is related to its dimensions, the bending diameter of the cable should exceed 10 times the cable diameter during handling or applications.

The loss (attenuation) of RF transmission lines is minimum at $Z_0 = 77 \Omega$ and the power handling capacity of the lines is maximum at $Z_0 = 30 \Omega$. Considering low loss requirements, characteristic impedance of 75Ω is standardised for video applications. Characteristic impedance of 50Ω is standardised for all other applications balancing loss and power handling requirements [4].

2.7 VSWR

2.7.1 Maximum Power Transfer

The acronym, VSWR, stands for Voltage Standing Wave Ratio. Figure 2.6 shows a series circuit having RF signal generator (source), a short length of RF coaxial transmission line and load impedance. The internal (output) impedance (Z_s) of the signal source is also shown. The transmission line is shown thick for simplicity.

Maximum power from the source is transferred to the load impedance when the output impedance of the RF signal source, characteristic impedance of the transmission line and the load impedance are matched. Assume that the output impedance (Z_s) of the RF signal source and the impedance of the transmission line (coaxial cable) are 50Ω . The power from the source is defined as incident power. If the load impedance in the RF circuit is also 50Ω i.e. matched to the impedance of transmission line and the RF source, maximum power transfer occurs from source to load. The incident power travels through the transmission line towards the load and it is fully absorbed by the load under matched conditions. If the source impedance is not resistive, then the load impedance must be complex conjugate of the source impedance for maximum power transfer. For example, if the source impedance is $(30 + j2) \Omega$, then the characteristic impedance of the transmission line must be $(30 + j2) \Omega$ and the load impedance must be $(30 - j2) \Omega$ for maximum power transfer.

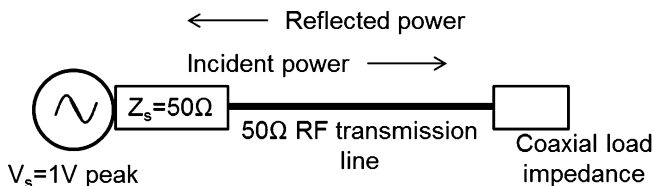

Fig. 2.6 RF transmission line circuit

If the load impedance is not matched to the impedance of RF circuit, some percentage of the incident power is returned i.e. reflected by the load towards the source through the transmission line. The quantum of the reflected power depends on the level of mismatch. If the load is open-circuit (load not connected to the transmission line) or the load is short circuit, the incident power is totally reflected at the end of the transmission line. The end of the transmission line is termed as the plane of the load. If the load impedance is partially matched (Ex: 40 or 60 Ω), then a fraction of the incident power is reflected back towards the source and the remaining power is absorbed by the load. The directions of incident power and the reflected power are shown in Fig. 2.6. Practical significance of VSWR is explained with an example.

2.7.2 Practical Significance of VSWR

Assume that a RF amplifier feeds an antenna through a RF coaxial feeder cable. The power amplifier is the RF source and the feeder cable is the transmission line. The antenna serves as the load impedance. Let the output impedance of the power amplifier and the characteristic impedance of the feeder cable is 50 Ω . Let the impedance of the antenna is 35 Ω , not matched to that of the source and the feeder cable. Due to impedance mismatch, a portion of the incident power is reflected by the antenna towards the amplifier and the remaining power is radiated. The reflected power is dissipated in the power amplifier and the dissipation could result in the premature (degradation) failure of the RF power transistor of the power amplifier. Customers experience poor reception due to the radiation of less power by the antenna. Hence, impedance matching is important for the satisfactory performance of RF systems. VSWR is a metric that measures how well the impedances of various components are matched in RF circuits and systems to realise maximum power transfer. VSWR has no units as it is a ratio of voltages.

VSWR is explained for four cases of load impedance i.e. open circuit, short circuit, matched (50 Ω) and partially matched (Ex.: 40 or 60 Ω), assuming the output impedance of the RF signal source and the impedance of the transmission line (coaxial cable) are 50 Ω . It is also assumed that the transmission line is *lossless* and the source delivers a sinusoidal voltage, V_s , of 1 V peak at microwave frequency, f (wave length, λ).

2.8 VSWR: Open Circuited Load

The transmission line circuit in Fig. 2.6 is modified and redrawn without load in Fig. 2.7, showing only one wave length (λ) of the RF transmission line and markers for every $\lambda/8$ from the load end. Assuming that the incident voltage wave

Fig. 2.7 RF transmission line—open circuit

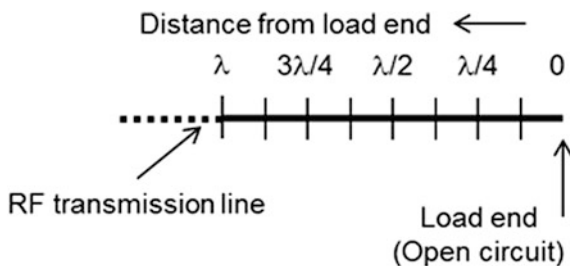

originates at a distance, λ , from the load end, the analysis of incident and reflected waves is presented for one wave length.

2.8.1 Relationship Between Incident and Reflected Voltages

The incident voltage wave sees an open circuit at the plane of the load and hence it is totally reflected by the load. The current at the end of the transmission line is zero. The frequency of the reflected voltage wave is same as that of the incident voltage wave. The magnitude and sign of the reflected wave are also same as those of the incident wave at the plane of the load so that the current is zero. For example, if the instantaneous incident voltage is -0.7 V at the plane of the load, the reflected voltage is also -0.7 V at the plane of the load. The reflected wave is in-phase with the incident wave.

The instantaneous voltages of incident and reflected waves are analysed using the in-phase relationship between the waves. For example, if the instantaneous incident voltage wave rises positively from 0 V at the point λ , the instantaneous reflected voltage wave also rises positively from 0 V at the load end. If the incident voltage wave falls negatively from -0.7 V at the point λ , the instantaneous reflected voltage wave also falls negatively from -0.7 V at the load end. The instantaneous voltages of incident and reflected waves are presented at eight different times.

2.8.2 Instantaneous Voltages of Incident, Reflected and Resultant Waves

To begin with, i.e. at time, $t = 0$, the instantaneous voltages of incident and reflected voltage waves having a peak voltage of 1 V are shown in Fig. 2.7a in dashed lines. The instantaneous voltages of incident and reflected waves are vectorially added and the resultant voltage waveform is also shown in Fig. 2.7a in continuous line. The voltage of the resultant wave is zero.

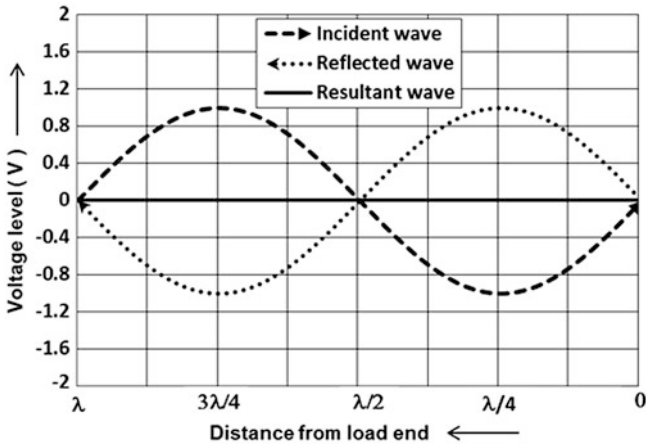

Fig. 2.7a Instantaneous voltages at $t = 0$ for open circuited line

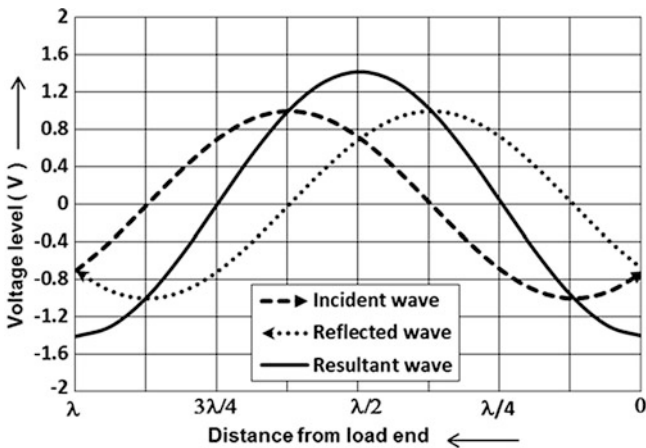

Fig. 2.7b Instantaneous voltages at $t = \lambda/8$ for open circuited line

At $t = \lambda/8$, the incident voltage wave advances by $\lambda/8$ towards the load and the reflected voltage wave also advances by $\lambda/8$ towards the source. The wave forms of incident voltage, reflected voltage and the resultant voltage at $t = \lambda/8$ are shown in Fig. 2.7b with the levels of instantaneous voltages. The peak voltage of the resultant voltage wave varies from -1.4 to $+1.4$ V.

Similarly, the instantaneous voltage levels of incident, reflected and the resultant waveforms are obtained at $t = \lambda/4$, $t = 3\lambda/8$, $t = \lambda/2$, $t = 5\lambda/8$, $t = 3\lambda/4$, $t = 7\lambda/8$ and $t = \lambda$ and they are shown in Fig. 2.7c-h respectively. It could be observed that the peak value of the resultant voltage waveform always occurs at $\lambda/2$ or its multiple from the open-circuited load end. Hence, the resultant wave is

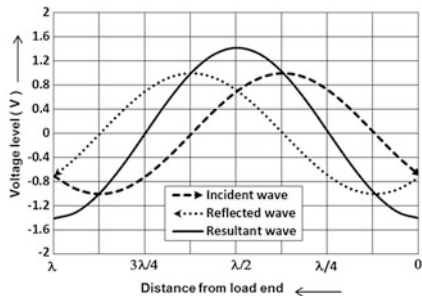

Fig. 2.7c Instantaneous voltages at $t = \lambda/4$ for open circuited line

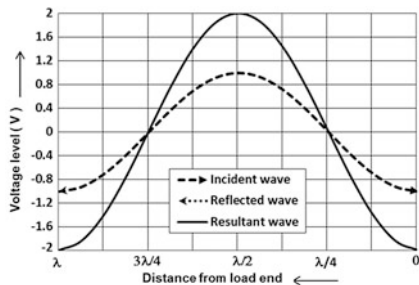

Fig. 2.7d Instantaneous voltages at $t = 3\lambda/8$ for open circuited line

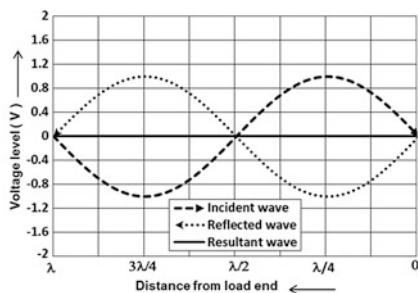

Fig. 2.7e Instantaneous voltages at $t = \lambda/2$ for open circuited line

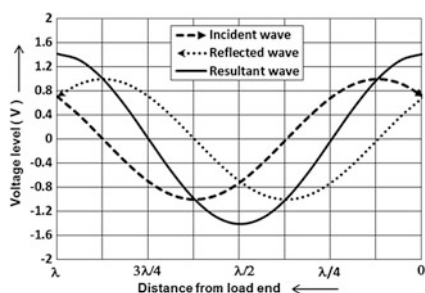

Fig. 2.7f Instantaneous voltages at $t = 5\lambda/8$ for open circuited line

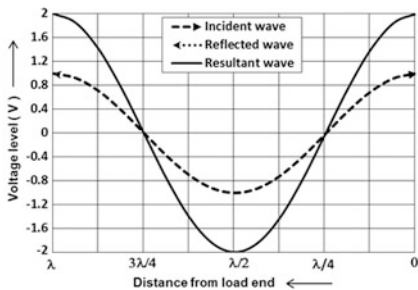

Fig. 2.7g Instantaneous voltages at $t = 3\lambda/4$ for open circuited line

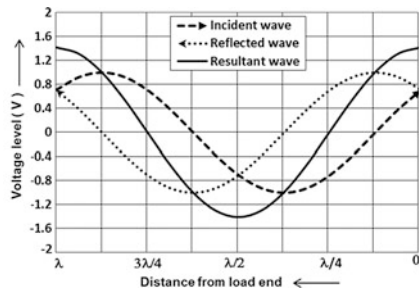

Fig. 2.7h Instantaneous voltages at $t = 7\lambda/8$ for open circuited line

considered stationary i.e. standing. The peak voltage of the standing wave varies from -2 to $+2$ V.

2.8.3 Standing Voltage Wave in Slotted Line

The obsolete Hewlett-Packard slotted line is quite useful in demonstrating the standing wave along the transmission line [5]. The slotted line is a specially designed precision rigid coaxial transmission line with air as dielectric. It has a narrow longitudinal slot along the outer conductor of the line. A capacitive probe is inserted into the slot for voltage sampling. There is a mechanical carriage arrangement to move the probe along the slot without contacting the walls of the slot. Moving the probe along the slot is equivalent to moving it along the transmission line.

Assume the slotted line set-up is connected to the open-circuited transmission line, which has standing voltage waveform varying from -2 to $+2$ V. The sampled voltage signal from the probe is fed to an effective (rms) voltage reading voltmeter. If the probe carriage is moved from the open circuited load end of the slotted line towards the RF signal source, the contour of the effective voltage of the standing wave would be as shown in Fig. 2.8 with its voltage level varying from 0V to 1.4 V for the lossless transmission line.

The minimum voltage, V_{\min} , is zero and the maximum voltage, V_{\max} , is 1.4 V rms for the standing wave voltage. Minimum voltage points are termed as nodes and maximum voltage points are termed as antinodes [2]. The ratio of maximum and minimum voltages of the standing wave is defined as VSWR. VSWR of the transmission line at the point of discontinuity i.e. open circuit is:

$$VSWR = V_{\max}/V_{\min} = 1.4\text{ V}/0\text{ V} = \infty$$

In practice, VSWR has a finite value V_{\max} is less than 1.4 V and V_{\min} is more than 0 V as transmission line has a finite loss. In the hp slotted line set-up, the sampled voltage output of the probe is connected to SWR meter, which, in combination with a square-law detector, indicates the measured VSWR directly.

Fig. 2.8 Standing wave voltage pattern for open circuited line

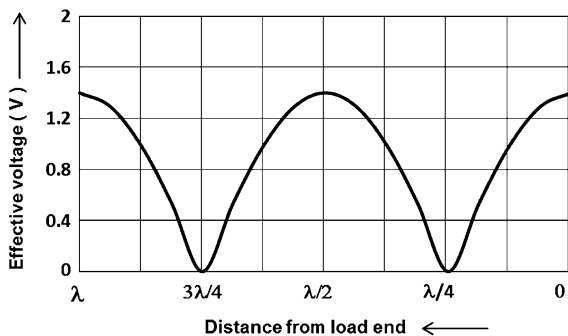
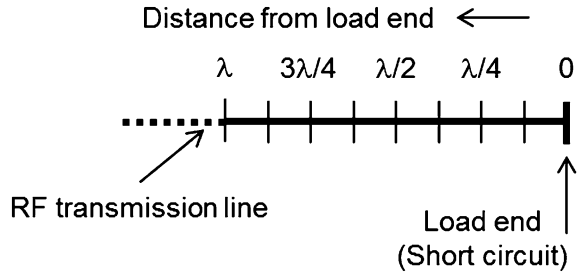

Fig. 2.9 RF transmission line—short circuit



2.9 VSWR: Short Circuited Load

The RF transmission line with its load end short circuited is shown in Fig. 2.9 for one wave length (λ) from the load end with markers for every $\lambda/8$. The short circuited end is shown by a thick line perpendicular to the transmission line. The concept of standing voltage wave generation is basically same as that of open circuited transmission line.

2.9.1 Relationship Between Incident and Reflected Voltages

The incident voltage wave sees a short circuit at the plane of the load, and hence it is totally reflected by the load. The voltage at the end of the transmission line is zero. The frequency of reflected voltage wave is same as that of incident voltage wave. The magnitude of the reflected voltage wave is also same as that of incident voltage wave but the voltages oppose each other at the load end so that the resultant voltage is zero. For example, if the instantaneous incident voltage is -0.7 V, the reflected voltage is $+0.7$ V at the plane of the load. The reflected voltage wave is out of phase with the incident wave.

The instantaneous voltages of incident and reflected waves are analysed using the out-of-phase relationship between the waves. For example, if the instantaneous incident voltage wave rises positively from 0 V at the point λ , the instantaneous reflected voltage wave falls negatively from 0 V at the load end. If the incident voltage wave falls negatively from -0.7 V at the point λ , the instantaneous reflected voltage wave rises positively from $+0.7$ V at the load end. The instantaneous voltages of incident and reflected waves are presented at eight different times.

2.9.2 Instantaneous Voltages of Incident, Reflected and Resultant Waves

The instantaneous voltage levels of incident, reflected and the resultant waves for $t = 0$ to $t = \lambda$ with intervals of $\lambda/8$ are shown in Fig. 2.10a–h. It could be observed

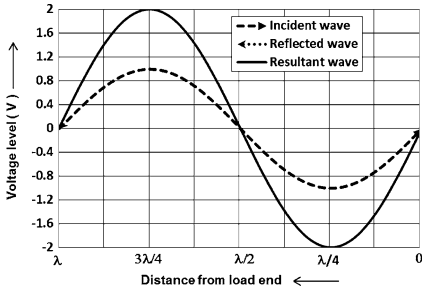

Fig. 2.10a $t = 0$ for short circuited line

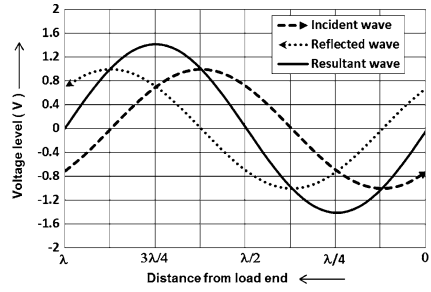

Fig. 2.10b $t = \lambda/8$ for short circuited line

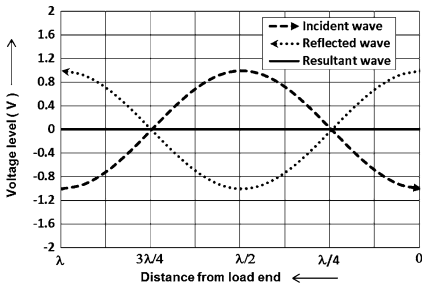

Fig. 2.10c $t = \lambda/4$ for short circuited line

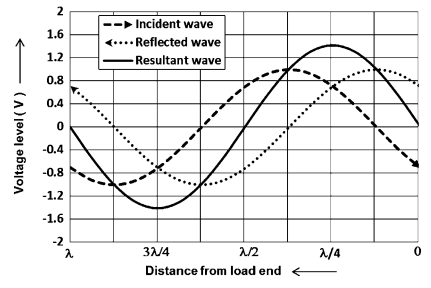

Fig. 2.10d $t = 3\lambda/8$ for short circuited line

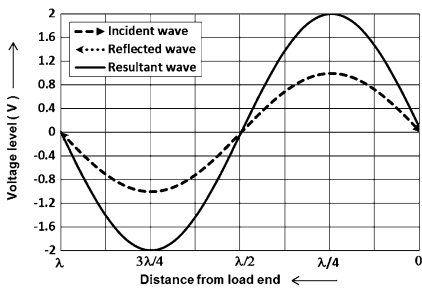

Fig. 2.10e $t = \lambda/2$ for short circuited line

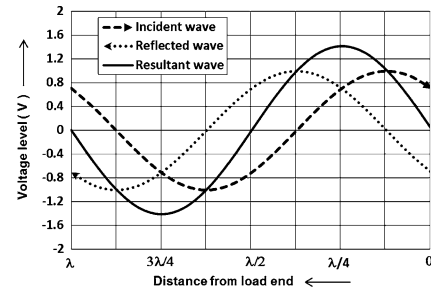

Fig. 2.10f $t = 5\lambda/8$ for short circuited line

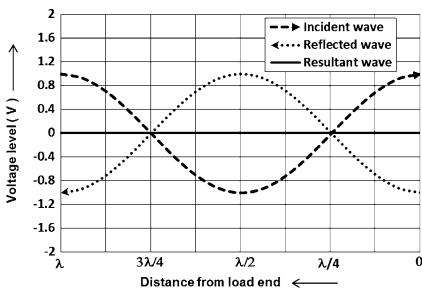

Fig. 2.10g $t = 3\lambda/4$ for short circuited line

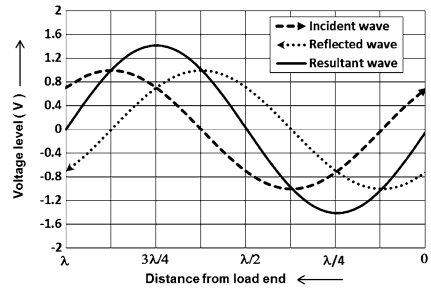

Fig. 2.10h $t = 7\lambda/8$ for short circuited line

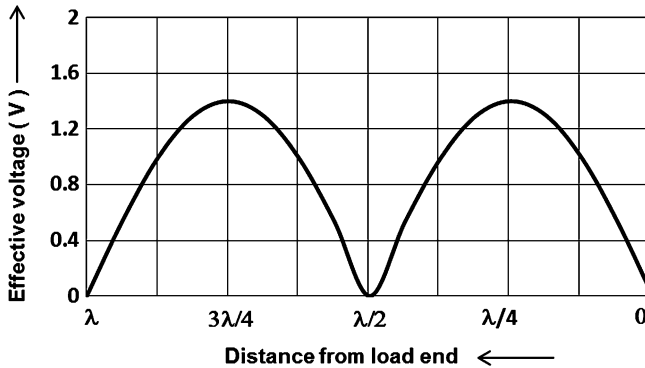

Fig. 2.11 Standing wave voltage pattern for short circuited line

that the peak value of the resultant standing voltage waveform always occurs at $\lambda/4$ or its multiple from the short-circuited load end. The peak voltage of the standing wave varies from -2 to $+2$ V.

In a slotted line set up, the contour of the effective voltage of the standing wave would be as shown in Fig. 2.11 with its voltage level varying from 0 V to 1.4 V for the lossless transmission line. For the RF transmission line with short circuit,

$$VSWR = V_{\max}/V_{\min} = 1.4\text{ V}/0\text{ V} = \infty$$

In practice, VSWR has a finite value V_{\max} is less than 1.4 V and V_{\min} is more than 0 V as transmission line has a finite loss.

2.10 VSWR: Matched 50 Ω Load

The RF transmission line, matched with 50 Ω load, is shown in Fig. 2.12 for one wave length (λ) from the load end. Markers are shown for every $\lambda/8$.

At the plane of the load, the incident voltage wave sees matched load and hence the incident wave is fully absorbed by the load. There is no reflected voltage wave. If an effective voltage reading voltmeter is moved along the transmission line from the load end, it reads a constant voltage, equal to the voltage across the load. For the source voltage of 1 V peak, the voltage across the load is 0.5 V peak and hence the rms voltmeter reads a constant voltage of $0.5/\sqrt{2}$ i.e. 0.35 V along the line as shown in Fig. 2.13.

$$V_{\max} = V_{\min} = 0.35\text{ V}$$

$$VSWR = V_{\max}/V_{\min} = 1 \text{ (Ideal value)}$$

In practice, VSWR is always greater than the ideal value as transmission line has a finite loss. Hence, the rms voltmeter of slotted line shows the presence of a

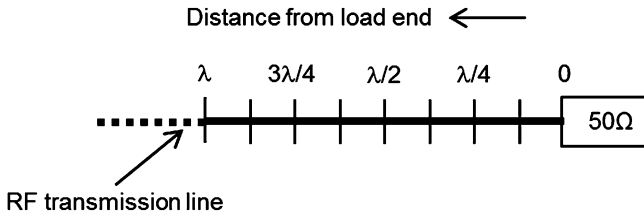

Fig. 2.12 RF transmission line—matched load

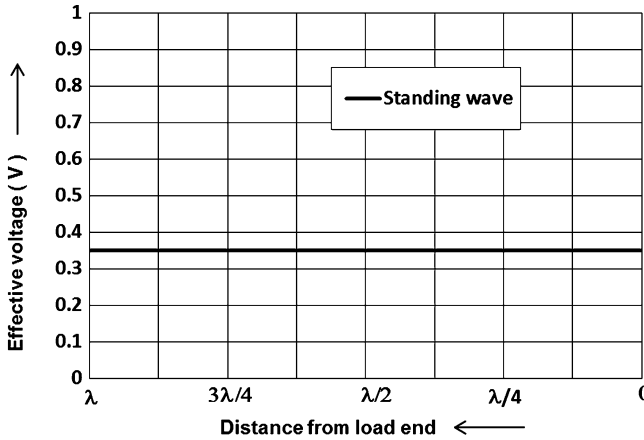

Fig. 2.13 Standing wave for transmission line with 50 Ω load

small ripple voltage instead of constant voltage. The precision hp slotted line explained earlier has a VSWR of less than 1.04.

2.11 VSWR: Infinitely Long 50 Ω Cable as Load

Figure 2.14 shows an infinitely long 50 Ω coaxial cable, connected to a transmission line instead of 50 Ω load impedance. Assume that the cable has a uniform characteristic impedance of 50 Ω and finite loss per meter.

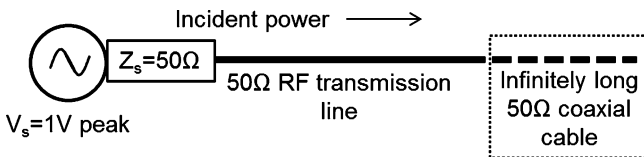

Fig. 2.14 Transmission line with 50 Ω cable

The incident voltage wave is attenuated by the cable and it does not reach the load end of the coaxial cable. Hence, there is no reflected voltage wave from the free end of the coaxial cable. It makes no difference whether the free end of the cable is open-circuited or short-circuited or connected to 50 Ω load impedance. The infinitely long coaxial cable itself behaves like a perfectly matched load. The ‘infinitely’ long coaxial cable concept is used to measure the VSWR characteristic of RF coaxial cables, known as Structural return loss of RF coaxial cables. The military specifications for RF coaxial connectors indicate that a RF coaxial cable is considered ‘infinitely’ long if the cable measures a loss of 26 dB or more at the test frequency.

2.12 VSWR: Partially Matched Load

The RF transmission line, partially matched load (less than 50 Ω or greater than 50 Ω), is shown in Fig. 2.15 for one wave length (λ) from the load end.

For load impedances greater than 50 Ω, the standing wave pattern is similar to open circuited transmission line i.e. the peak value of the standing wave always occurs at λ/2 or its multiple from the load end. For load impedances less than 50 Ω, the standing wave pattern is similar to short circuited transmission line i.e.

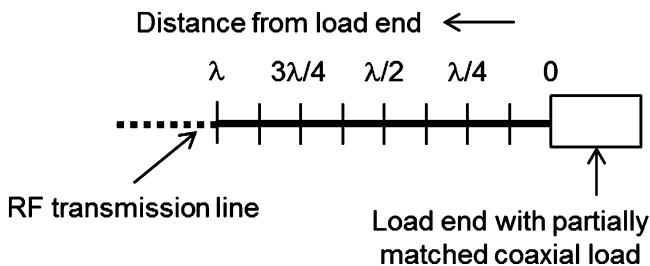

Fig. 2.15 Transmission line with partially matched load

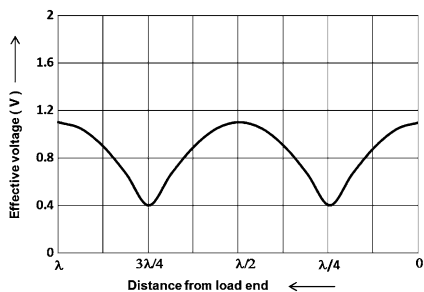

Fig. 2.16 Standing wave for Z > 50 Ω

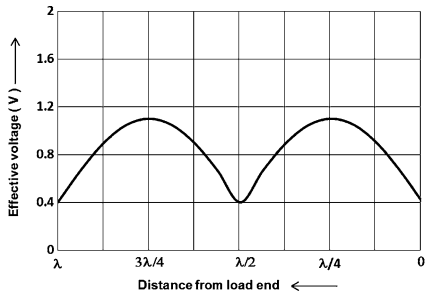

Fig. 2.17 Standing wave for Z < 50 Ω

the peak value of the standing wave always occurs at $\lambda/4$ or its multiple from the load end. The values of V_{\max} and V_{\min} depend on the deviation load impedance from 50Ω . The effective (rms) standing voltage waveforms for the load impedances are shown in Figs. 2.16 and 2.17.

The values of V_{\max} and V_{\min} depend upon the amount of mismatch and other losses in transmission line. Any text book on RF transmission lines or the text book mentioned in the reference-3 could be referred for the mathematical analysis of incident and reflected waves.

References

1. Cripps SC (2008) Pulling up. IEEE Microwave Mag 9:40–48
2. Ryder JD (1965) Networks, lines and fields. Prentice-Hall, Inc., NJ
3. Matthei GL, Young L, Jones EMT (1980) Microwave filters, impedance-matching networks, and coupling structures. Artech House
4. Agilent Network Analyser Basics (2004) Agilent Technologies, Inc., 5965–7917E
5. HP Journal (1950) Greater reliability in UHF impedance measurements, Technical Information from the Hewlett-Packard Laboratories, vol 1