

# II.

## Theorem of Borsuk and Topological Transversality

---

In this chapter we provide an easily accessible and unified account of some of the most fundamental results in fixed point theory. Among them, the antipodal theorem of Borsuk and the theorem on topological transversality occupy the central position; all the other results in this chapter are their consequences. The chapter ends with diverse applications to various fields.

### §5. Theorems of Brouwer and Borsuk

Our aim in this paragraph is to establish the theorem of Borsuk and its immediate consequence, the Brouwer fixed point theorem. We obtain these results by first establishing the Lusternik–Schnirelmann–Borsuk theorem about the  $n$ -sphere. Our approach is elementary, in that it involves only some simple simplicial decompositions of the sphere and a combinatorial lemma.

#### 1. Preliminary Remarks

Let  $E$  be a normed linear space. We recall that a finite set of  $s + 1$  points in  $E$  is said to be *affinely independent* if it is not contained in any  $(s - 1)$ -flat of  $E$ .

(1.1) DEFINITION. Let  $\{p_0, p_1, \dots, p_s\}$  be an affinely independent set of  $s + 1$  points in  $E$ . Their convex hull

$$\left\{ x \in E \mid x = \sum_{i=0}^s \lambda_i p_i; 0 \leq \lambda_i \leq 1, \sum_{i=0}^s \lambda_i = 1 \right\}$$

is called the (closed)  $s$ -simplex with vertices  $p_0, \dots, p_s$  and is denoted by  $[p_0, \dots, p_s]$ . If the vertices do not have to be explicitly stated, a simplex is denoted by  $\sigma$  or  $\sigma^s$ , the upper index indicating its dimension.

The  $k$ -simplex spanned by any  $k + 1$  of the vertices  $p_0, \dots, p_s$  is called a  $k$ -face of  $\sigma^s$ ; the only  $s$ -face of  $\sigma^s$  is  $\sigma^s$  itself. The *boundary*,  $\partial\sigma^s$  (which is not necessarily the topological boundary of  $\sigma^s$  in  $E$ ), is the union of all faces of dimension  $\leq s - 1$ ; the *open  $s$ -simplex* is  $\sigma^s - \partial\sigma^s$ . The 0-faces of  $\sigma^s$  are its vertices, and the 1-faces  $[p_i, p_j]$  are called the *edges* of  $\sigma^s$ ; because  $\sigma^s$  is convex, it is easy to see that the diameter  $\delta(\sigma^s)$  of  $\sigma^s$  is the length of its longest edge.

A simplex is obviously a compact metric space. Moreover, because the set of its vertices is affinely independent, each  $x \in \sigma^s = [p_0, \dots, p_s]$  can be written uniquely as  $x = \sum_{i=0}^s \lambda_i(x)p_i$ , where  $\sum_{i=0}^s \lambda_i(x) = 1$  and  $0 \leq \lambda_i(x) \leq 1$  for each  $x \in \sigma^s$  and  $i = 0, \dots, s$ ; the  $(s+1)$ -tuple  $(\lambda_0(x), \dots, \lambda_s(x))$  of real numbers is called the *barycentric coordinates* of  $x \in \sigma$ , and each  $\lambda_i : \sigma \rightarrow [0, 1]$  is called the  $i$ th *barycentric coordinate function* of  $\sigma$ .

(1.2) PROPOSITION. *Any two  $s$ -simplices are affinely homeomorphic. Furthermore, for any simplex  $\sigma$ , each of its barycentric coordinate functions  $\lambda_i : \sigma \rightarrow [0, 1]$  is continuous.*

PROOF. Let  $\mathbf{R}^{s+1}$  be the  $(s + 1)$ -dimensional Euclidean space and  $\Delta^s \subset \mathbf{R}^{s+1}$  be the  $s$ -simplex having the unit points  $e_0 = (1, 0, \dots, 0), \dots, e_s = (0, 0, \dots, 1)$  in  $\mathbf{R}^{s+1}$  as vertices;  $\Delta^s$  is called the *standard  $s$ -simplex*. Observe that the barycentric coordinates of any  $x \in \Delta^s$  are precisely the Euclidean coordinates of  $x$ , so that

$$\Delta^s = \left\{ (\lambda_0, \dots, \lambda_s) \in \mathbf{R}^{s+1} \mid 0 \leq \lambda_i \leq 1, \sum_{i=0}^s \lambda_i = 1 \right\}.$$

We now show that any given  $\sigma^s = [p_0, \dots, p_s] \subset E$  is affinely homeomorphic to  $\Delta^s$ . Let  $h : \mathbf{R}^{s+1} \rightarrow E$  be the map  $h(\lambda_0, \dots, \lambda_s) = \sum_{i=0}^s \lambda_i p_i$ ; this is clearly continuous, and  $g = h|_{\Delta^s}$  maps  $\Delta^s$  onto  $\sigma^s$ ; since  $g$  is also a bijective map of the compact  $\Delta^s$  onto  $\sigma^s$ , we conclude that  $g$  is an affine homeomorphism of  $\Delta^s$  onto  $\sigma^s$ . To prove that the barycentric coordinate functions are continuous, let  $\pi_i : \mathbf{R}^{s+1} \rightarrow \mathbf{R}$  be the projection onto the  $i$ th coordinate space; since  $\lambda_i = \pi_i \circ g^{-1}$ , and both  $\pi_i, g^{-1}$  are continuous, the proof is complete.  $\square$

## 2. Basic Triangulation of $S^n$

Because we will be using simplices throughout, it is convenient to work with an equivalent norm for Euclidean space under which the unit sphere can be regarded as the union of geometric simplices.

Let  $E$  be the normed space of all those sequences  $x = \{x_1, x_2, \dots\}$  of real numbers having at most finitely many  $x_n \neq 0$ , with the norm  $\|x\| = \sum |x_i|$ .

The subset  $\{x \in E \mid x_i = 0 \text{ for all } i > n\}$  is denoted by  $E^n$ ; the (closed) *unit  $n$ -ball* is

$$K^n = \{x \in E^n \mid \|x\| \leq 1\}.$$

The *unit  $n$ -sphere* is  $S^n = \{x \in E^{n+1} \mid \|x\| = 1\}$ ; its upper hemisphere is  $S_+^n = \{x \in S^n \mid x_{n+1} \geq 0\}$ , and its lower hemisphere is  $S_-^n = \{x \in S^n \mid x_{n+1} \leq 0\}$ ; clearly,  $S^n = S_+^n \cup S_-^n$ . Observe that for any  $k < n$ , we have

$$S^k = \{x \in S^n \mid x_{k+2} = \cdots = x_{n+1} = 0\}$$

and that  $S^{n-1} = S_+^n \cap S_-^n$ .

Given an  $n$ -dimensional normed linear space  $L^n$  it is easy to see that there is a homeomorphism of  $L^n$  onto  $E^n$  sending points symmetric with respect to the origin in  $L^n$  onto points symmetric with respect to the origin in  $E^n$  and mapping the unit sphere in  $L^n$  onto  $S^n$ . Therefore, the results that will be established in this paragraph in  $E^n$  remain valid for any finite-dimensional normed linear space  $L^n$ .

By a triangulation of  $S^n$  is meant a decomposition of  $S^n$  into simplices that are pasted together along common faces in an orderly manner. Precisely:

(2.1) DEFINITION. A finite family  $\mathcal{S}^n = \{\sigma\}$  of simplices in  $S^n$  is called a *triangulation* of  $S^n$  provided:

- (i) the intersection of any two simplices in  $\mathcal{S}^n$  is either empty or a common face of each,
- (ii) if  $\sigma \in \mathcal{S}^n$  then every face of  $\sigma$  is in  $\mathcal{S}^n$ ,
- (iii)  $S^n = \bigcup\{\sigma \mid \sigma \in \mathcal{S}^n\}$ .
- (iv) each  $(n - 1)$ -simplex of  $\mathcal{S}^n$  is the common face of exactly two  $n$ -simplices in  $\mathcal{S}^n$ .

We remark that (iv) can be deduced from properties (i)–(iii).

The following triangulation of  $S^n$  is important for our purposes: For each  $i = 1, \dots, n + 1$ , let  $e_i = \{\delta_1^i, \delta_2^i, \dots\} \in E$ , where  $\delta_j^i$  is the Kronecker delta; clearly, the unit ball  $K^{n+1}$  is precisely the convex hull of the set  $\{e_1, \dots, e_{n+1}, -e_1, \dots, -e_{n+1}\}$ . It is easy to see that the set of all  $n$ -simplices  $[\pm e_1, \dots, \pm e_{n+1}]$  and all their faces provides a triangulation of  $S^n$ , called the *basic triangulation*; this triangulation is denoted by  $\Sigma^n$ . Note that each simplex of  $\Sigma^n$  has a unique representation (called its *standard form*) by a symbol  $[\pm e_{i_0}, \dots, \pm e_{i_s}]$ , where  $i_0 < \cdots < i_s$ .

Let  $\alpha : S^n \rightarrow S^n$  be the *antipodal map*  $x \mapsto -x$ ; two elements of any sort (points, simplices, sets) corresponding under  $\alpha$  will be called *antipodal*. Note that for each  $k \leq n$ , the restriction  $\alpha|S^k$  is the antipodal map of  $S^k$ . It is clear that no simplex of  $\Sigma^n$  contains a pair of antipodal vertices, and

that for each simplex  $\sigma^k \in \Sigma^n$  the set  $\alpha(\sigma^k)$  is also a simplex of  $\Sigma^n$ . Since we need to consider triangulations of  $\mathbf{S}^n$  other than  $\Sigma^n$  that have these two properties, we make the formal

- (2.2) DEFINITION. A triangulation  $\mathcal{S}^n$  of  $\mathbf{S}^n$  is called *symmetric* if:
- (a) for each  $k \leq n$ , the  $k$ -sphere  $\mathbf{S}^k$  is a union of  $k$ -simplices of  $\mathcal{S}^n$ ,
  - (b) for each  $k \leq n$ , and each simplex  $\sigma^k \in \mathcal{S}^n$ , the set  $\alpha(\sigma^k)$  is also a  $k$ -simplex of  $\mathcal{S}^n$ .

We have already observed that  $\Sigma^n$  is a symmetric triangulation; moreover, symmetric triangulations of  $\mathbf{S}^n$  with arbitrarily small simplices clearly exist; a formal inductive proof of this evident geometric fact could be based on the observations that a symmetric small simplex triangulation of  $\mathbf{S}^n = \partial\mathbf{S}_-^{n+1}$  can be extended to a small simplex simplicial decomposition of  $\mathbf{S}_-^{n+1}$ , and that

$$\{\sigma^{n+1}, \alpha(\sigma^{n+1}) \mid \sigma^{n+1} \in \mathbf{S}_-^{n+1}\}$$

is then a symmetric triangulation of  $\mathbf{S}^{n+1}$ .

### 3. A Combinatorial Lemma

Let  $\mathcal{S}^k$ , respectively  $\mathcal{S}^n$ , be triangulations of  $\mathbf{S}^k$ , respectively  $\mathbf{S}^n$ . A map  $f$  of the vertices of  $\mathcal{S}^k$  to the vertices of  $\mathcal{S}^n$  is called a *simplicial vertex map* if for each simplex  $[p_0, \dots, p_s]$  of  $\mathcal{S}^k$ , the points  $f(p_0), \dots, f(p_s)$  are the vertices of a (possibly lower-dimensional) simplex of  $\mathcal{S}^n$ . Clearly,  $f$  extends to a map  $\mathbf{S}^k \rightarrow \mathbf{S}^n$  (denoted also by  $f$ ) sending simplices of  $\mathcal{S}^k$  into simplices of  $\mathcal{S}^n$ .

- (3.1) DEFINITION. Let  $\mathcal{S}^k$  be an arbitrary triangulation of  $\mathbf{S}^k$ , and let  $f : \mathcal{S}^k \rightarrow \Sigma^n$  be a simplicial vertex map. An  $r$ -simplex  $[p_0, \dots, p_r]$  of  $\mathcal{S}^k$  is called *positive* if:
- (i) the vertices  $f(p_0), \dots, f(p_r)$  span an  $r$ -simplex  $\sigma^r \in \Sigma^n$ ,
  - (ii) the standard form of  $\sigma^r$  is “alternating in sign”,

$$\sigma^r = [+e_{i_0}, -e_{i_1}, \dots, (-1)^r e_{i_r}],$$

with the first vertex positive.

An  $r$ -simplex of  $\mathcal{S}^k$  is *negative* if its  $f$ -image is an  $r$ -simplex of  $\Sigma^n$  which, in standard form, is alternating in sign and has negative first vertex.

An  $r$ -simplex of  $\mathcal{S}^k$  that is neither positive nor negative is called *neutral*.

For any simplicial vertex map  $f : \mathcal{S}^k \rightarrow \Sigma^n$  and any subset  $L \subset \mathbf{S}^k$ , the number of positive  $r$ -simplices in  $L$  under  $f$  is denoted by  $p(f, L, r)$ .

The main result of this section relies on the following

(3.2) PROPOSITION. *Let  $k \leq n$ , and let  $f : \mathcal{S}^k \rightarrow \Sigma^n$  be a simplicial vertex map of a symmetric triangulation of  $\mathbf{S}^k$  into  $\Sigma^n$ . If  $\alpha \circ f = f \circ \alpha$ , then*

$$p(f, \mathbf{S}^k, k) \equiv p(f, \mathbf{S}^{k-1}, k-1) \pmod{2}.$$

PROOF. Consider the upper hemisphere  $\mathbf{S}_+^k$  of  $\mathbf{S}^k$ , and decompose the set of  $k$ -simplices in  $\mathbf{S}_+^k$  into three disjoint classes:

$$\begin{aligned} \mathcal{A}_+ &= \{s^k \subset \mathbf{S}_+^k \mid s^k \text{ is positive}\}, \\ \mathcal{A}_- &= \{s^k \subset \mathbf{S}_+^k \mid s^k \text{ is negative}\}, \\ \mathcal{A}_0 &= \{s^k \subset \mathbf{S}_+^k \mid s^k \text{ is neutral}\}. \end{aligned}$$

Consider the sum

$$T = \sum_{s^k \in \mathcal{A}_+} p(f, s^k, k-1) + \sum_{s^k \in \mathcal{A}_-} p(f, s^k, k-1) + \sum_{s^k \in \mathcal{A}_0} p(f, s^k, k-1);$$

we will determine the parity of  $T$ .

First note that, because each  $p(f, s^k, k-1)$  is the number of positive  $(k-1)$ -faces of  $s^k$ , the sum  $T$  involves all the positive  $s^{k-1}$  in  $\mathbf{S}_+^k$ . Observe next that each positive  $s^{k-1}$  not in  $\mathbf{S}^{k-1}$  will occur twice in the sum  $T$ , since it is a face of exactly two  $s^k$ ; because each positive  $s^{k-1}$  on  $\mathbf{S}^{k-1}$  is the face of only one  $s^k \in \mathbf{S}_+^k$ , we conclude that  $T \equiv p(f, \mathbf{S}^{k-1}, k-1) \pmod{2}$ .

We now develop another expression for  $T$ . Consider any neutral  $s^k$ . Since  $s^k$  can have no positive  $(k-1)$ -face (hence make no contribution to the sum), unless  $\dim f(s^k) \geq k-1$ , we can write  $f(s^k) = [\pm e_{i_0}, \dots, \pm e_{i_k}]$  with  $i_0 \leq \dots \leq i_k$ , in which there is either one repeated vertex, or all the vertices are distinct but the signs do not alternate. In each case, a positive  $(k-1)$ -face can occur only if there is at most one pair of adjacent vertices with the same sign; and if removal of one of these vertices gives a positive face, so also will removal of the adjacent one. Thus,  $p(f, s^k, k-1)$  is even for each  $s^k \in \mathcal{A}_0$ , so that

$$T \equiv \sum_{s^k \in \mathcal{A}_+} p(f, s^k, k-1) + \sum_{s^k \in \mathcal{A}_-} p(f, s^k, k-1) \pmod{2}.$$

Noting now that each positive  $s^k$  has exactly one positive  $(k-1)$ -face, as also does each negative  $s^k$ , we find

$$\sum_{s^k \in \mathcal{A}_+} p(f, s^k, k-1) = \text{card } \mathcal{A}_+, \quad \sum_{s^k \in \mathcal{A}_-} p(f, s^k, k-1) = \text{card } \mathcal{A}_-,$$

and therefore

$$T \equiv (\text{card } \mathcal{A}_+ + \text{card } \mathcal{A}_-) \pmod{2}.$$

Finally, as  $\alpha \circ f = f \circ \alpha$ , it follows that an  $s^k \in \mathbf{S}_+^k$  is negative if and only if  $\alpha(s^k) \in \mathbf{S}_-^k$  is positive, so that  $\text{card } \mathcal{A}_- = \text{card}\{s^k \in \mathbf{S}_-^k \mid s^k \text{ is positive}\}$ ; therefore  $\text{card } \mathcal{A}_+ + \text{card } \mathcal{A}_- = p(f, \mathbf{S}^k, k)$ , and the proof is complete.  $\square$

Proposition (3.2) leads to the main result of this section:

(3.3) **THEOREM (Combinatorial lemma).** *Let  $f : \mathcal{S}^n \rightarrow \Sigma^n$  be a simplicial vertex map of a symmetric triangulation of  $\mathbf{S}^n$ . If  $\alpha \circ f = f \circ \alpha$ , then  $f$  maps an odd number of simplices of  $\mathbf{S}^n$  onto*

$$\sigma_0^n = [e_1, -e_2, \dots, (-1)^n e_{n+1}].$$

**PROOF.** According to the definition, an  $s^n \in \mathcal{S}^n$  is positive if and only if its image, in standard form, is  $\sigma_0^n$ . According to the lemma,

$$p(f, \mathbf{S}^n, n) \equiv p(f, \mathbf{S}^{n-1}, n-1) \equiv \dots \equiv p(f, \mathbf{S}^0, 0) \pmod{2}.$$

As  $\mathbf{S}^0$  consists of exactly two vertices and  $f|_{\mathbf{S}^0}$  maps them onto a pair of antipodal vertices, it is clear that  $p(f, \mathbf{S}^0, 0) = 1$ , completing the proof.  $\square$

#### 4. The Lusternik–Schnirelmann–Borsuk Theorem

The combinatorial lemma will be applied to obtain the Lusternik–Schnirelmann–Borsuk theorem about the  $n$ -sphere, which is equivalent to the Borsuk antipodal theorem.

(4.1) **LEMMA (Lebesgue).** *Let  $\{M_1, \dots, M_n\}$  be a family of closed non-empty sets in a compact metric space  $X$ , with  $M_1 \cap \dots \cap M_n = \emptyset$ . Then there exists an  $\varepsilon > 0$  with the property: any subset  $A \subset X$  meeting every  $M_i$  must have  $\delta(A) \geq \varepsilon$ .*

**PROOF.** Let  $Z$  be the compact metric space  $M_1 \times \dots \times M_n$  and consider the continuous  $\lambda : Z \rightarrow \mathbf{R}$  defined by

$$(x_1, \dots, x_n) \mapsto \max\{d(x_i, x_j) \mid 1 \leq i < j \leq n\}.$$

Because  $M_1 \cap \dots \cap M_n = \emptyset$ , the map  $\lambda$  is never zero; consequently, it assumes a minimum,  $\varepsilon > 0$ . If  $A \subset X$  meets each  $M_i$ , there is an  $x_i \in A \cap M_i$  for each  $i = 1, \dots, n$ ; since  $\lambda(x_1, \dots, x_n) \geq \varepsilon$ , at least one  $d(x_i, x_j) \geq \varepsilon$ , so  $\delta(A) \geq \varepsilon$ . This completes the proof.  $\square$

As an immediate consequence, we have

(4.2) **THEOREM (Lebesgue).** *Let  $\{M_1, \dots, M_n\}$  be a closed covering of a compact metric space  $X$ . Then there exists a  $\lambda > 0$  (a Lebesgue number of the covering) with the property: if any set  $A$  of diameter  $< \lambda$  meets  $M_{i_1}, \dots, M_{i_r}$ , then*

$$M_{i_1} \cap \dots \cap M_{i_r} \neq \emptyset. \quad \square$$

With these preliminaries, we are ready to establish the fundamental

(4.3) LEMMA. *Let  $M_1, \dots, M_{n+1}$  be  $n + 1$  closed sets on  $\mathbf{S}^n$ , no one of which contains a pair of antipodal points. If the family*

$$\{M_1, \dots, M_{n+1}, \alpha(M_1), \dots, \alpha(M_{n+1})\}$$

*covers  $\mathbf{S}^n$ , then  $M_1 \cap \dots \cap M_{n+1} \neq \emptyset$ .*

PROOF. Denote  $\alpha(M_i)$  by  $M_{-i}$ ; since  $M_i$  does not contain any pair of antipodal points, we have  $d(M_i, M_{-i}) = \varepsilon_i > 0$  for each  $i = 1, \dots, n + 1$ .

Linearly order the covering by

$$M_1, M_{-1}; M_{-2}, M_2; M_3, M_{-3}; M_{-4}, M_4; \dots,$$

and let  $\lambda$  be a Lebesgue number for this closed covering.

Let  $\mathcal{S}^n$  be a symmetric triangulation of  $\mathbf{S}^n$  with the diameter of each simplex  $< \varepsilon = \min(\lambda, \varepsilon_1, \dots, \varepsilon_{n+1})$ . We first construct a simplicial vertex map  $f : \mathcal{S}^n \rightarrow \Sigma^n$  as follows:

For each vertex  $p \in \mathcal{S}^n$ , let  $M_j$  be the first set of the ordered covering containing  $p$ , and set

$$f(p) = (\text{sign } j)(-1)^{j+1} e_{|j|}.$$

This is, in fact, a simplicial vertex map: since  $\Sigma^n$  can be described as the set of all simplices  $[\pm e_{i_0}, \dots, \pm e_{i_s}]$  with no two entries antipodal, it is enough to show that no two vertices  $p_i, p_j$  of a simplex of  $\mathcal{S}^n$  can map to antipodal vertices, and this follows from  $d(p_i, p_j) < \varepsilon$  and the definition of  $\varepsilon$ .

It is evident, from the definition of  $f$ , that  $\alpha \circ f = f \circ \alpha$ , so from (3.3), there is some simplex  $[p_1, \dots, p_{n+1}]$  such that

$$f[p_1, \dots, p_{n+1}] = [e_1, -e_2, \dots, (-1)^n e_{n+1}].$$

This means that each  $p_i \in M_i$ , so that  $[p_1, \dots, p_{n+1}] \cap M_i \neq \emptyset$  for  $i = 1, \dots, n + 1$ . Since  $\delta([p_1, \dots, p_{n+1}]) < \lambda$ , it follows that  $M_1 \cap \dots \cap M_{n+1} \neq \emptyset$ , and the proof is complete.  $\square$

We now establish the main result of this section.

(4.4) THEOREM (Lusternik–Schnirelmann–Borsuk). *In any closed covering  $\{M_1, \dots, M_{n+1}\}$  of  $\mathbf{S}^n$  by  $n + 1$  sets, at least one set  $M_i$  must contain a pair of antipodal points.*

PROOF. We argue by contradiction. Assume that no  $M_i$  contains a pair of antipodal points; then (4.3) applied to the covering  $\{M_1, \dots, M_{n+1}, \alpha(M_1), \dots, \alpha(M_{n+1})\}$  would show  $M_1 \cap \dots \cap M_{n+1} \neq \emptyset$ ; since any  $x_0 \in M_1 \cap \dots \cap M_{n+1}$  must also be in some set  $\alpha(M_j)$  of the covering  $\{\alpha(M_1), \dots, \alpha(M_{n+1})\}$  of  $\mathbf{S}^n$ , this means that  $M_j$  would contain a pair of antipodal points, contradicting our hypothesis and completing the proof.  $\square$

### 5. Equivalent Formulations. The Borsuk–Ulam Theorem

Results equivalent to the Lusternik–Schnirelmann–Borsuk theorem use the notions of extendability and homotopy in their formulation. For the convenience of the reader, and to establish the terminology, we recall the relevant definitions. By space we understand a Hausdorff space; unless specifically stated otherwise, a map is a continuous transformation.

(a) Let  $X, Y$  be two spaces and  $A \subset X$ . A map  $f : A \rightarrow Y$  is called *extendable over  $X$*  if there is a map  $F : X \rightarrow Y$  with  $F|_A = f$ .

(b) Two maps  $f, g : X \rightarrow Y$  are called *homotopic* if there is a map  $H : X \times \mathbf{I} \rightarrow Y$  with  $H(x, 0) = f(x)$  and  $H(x, 1) = g(x)$  for each  $x \in X$ . The map  $H$  is called a *homotopy* (or *continuous deformation*) of  $f$  to  $g$ , and written  $H : f \simeq g$ . For each  $t$ , the map  $x \mapsto H(x, t)$  is denoted by  $H_t : X \rightarrow Y$ ; clearly the family  $\{H_t : X \rightarrow Y\}_{0 \leq t \leq 1}$  determines  $H$  and vice versa.

Recall that the relation of homotopy is an equivalence relation in the set of all continuous maps of  $X$  into  $Y$ ; for reflexivity, note  $H(x, t) \equiv f(x)$  shows  $f \simeq f$ ; for symmetry, observe that if  $H : f \simeq g$  then  $(x, t) \mapsto H(x, 1 - t)$  gives  $g \simeq f$ ; if  $H : f \simeq g$  and  $G : g \simeq h$ , then

$$D(x, t) = \begin{cases} H(x, 2t), & 0 \leq t \leq \frac{1}{2}, \\ G(x, 2t - 1), & \frac{1}{2} \leq t \leq 1, \end{cases}$$

is continuous and shows that  $f \simeq h$ , establishing transitivity. Thus, the relation of homotopy decomposes the set of all maps of  $X$  into  $Y$  into pairwise disjoint classes called *homotopy classes*. An  $f : X \rightarrow Y$  homotopic to a constant map is called *nullhomotopic*; in this case we write  $f \simeq 0$ . A space  $X$  is called *contractible* if  $\text{id}_X : X \rightarrow X$  is nullhomotopic.

Observe that to establish a homotopy  $H : f \simeq g$  is essentially an extendability problem: one has given a map  $h : (X \times 0) \cup (X \times 1) \rightarrow Y$  and seeks an extension over  $X \times \mathbf{I}$ . For the special case of maps of spheres into arbitrary spaces, their nullhomotopy is equivalent to a simpler extendability property, which is very frequently used:

(5.1) THEOREM. *A map  $f : \mathbf{S}^n \rightarrow Y$  is nullhomotopic if and only if  $f$  is extendable to an  $F : \mathbf{K}^{n+1} \rightarrow Y$ .*

PROOF. Assume  $f : \mathbf{S}^n \rightarrow Y$  is extendable to  $F : \mathbf{K}^{n+1} \rightarrow Y$ . For  $x \in \mathbf{S}^n$  and  $0 \leq t \leq 1$ , set  $H(x, t) = F(tx)$  to see that  $H : 0 \simeq f$ . Conversely, if  $H : \mathbf{S}^n \times \mathbf{I} \rightarrow Y$  shows  $0 \simeq f$ , define an extension  $F : \mathbf{K}^{n+1} \rightarrow Y$  of  $f$  by

$$F(y) = \begin{cases} H(\mathbf{S}^n, 0), & 0 \leq \|y\| \leq \frac{1}{2}, \\ H(y/\|y\|, 2\|y\| - 1), & \frac{1}{2} \leq \|y\| \leq 1. \end{cases}$$

This completes the proof. □

We say that  $f : \mathbf{S}^n \rightarrow \mathbf{S}^k$  is *antipode-preserving* if  $f(-x) = -f(x)$  for all  $x \in \mathbf{S}^n$ . With this terminology we now prove Borsuk's antipodal theorem and also show that it is equivalent to various geometric results about the  $n$ -sphere. A fixed point version of the theorem will be derived in the next section.

(5.2) THEOREM. *The following statements are equivalent:*

- (1) *The Lusternik–Schnirelmann–Borsuk theorem.*
- (2) *There is no antipode-preserving map  $f : \mathbf{S}^n \rightarrow \mathbf{S}^{n-1}$ .*
- (3) *(Borsuk's antipodal theorem) An antipode-preserving map  $f : \mathbf{S}^{n-1} \rightarrow \mathbf{S}^{n-1}$  is not nullhomotopic.*
- (4) *(Borsuk–Ulam) Every continuous  $f : \mathbf{S}^n \rightarrow E^n$  sends at least one pair of antipodal points to the same point.*

PROOF. (1) $\Rightarrow$ (2). Suppose  $f : \mathbf{S}^n \rightarrow \mathbf{S}^{n-1}$  is antipode-preserving. Decompose  $\mathbf{S}^{n-1}$  into  $n + 1$  closed sets  $A_1, \dots, A_{n+1}$  by projecting the boundary of an  $n$ -simplex centered at 0 onto  $\mathbf{S}^{n-1}$  and letting  $A_i$  be the images of the  $(n - 1)$ -faces. Clearly, no  $A_i$  contains a pair of antipodal points.

Let  $M_i = f^{-1}(A_i)$ ,  $i = 1, \dots, n + 1$ . The  $M_i$  are closed and cover  $\mathbf{S}^n$ , so by (1), there is an  $x \in M_i \cap \alpha M_i$  for some  $i$ . Because  $f$  is antipode-preserving, this means that  $f(x)$  and  $f\alpha(x) = \alpha f(x)$  both belong to  $A_i$ , which is a contradiction.

(2) $\Rightarrow$ (3). Suppose some antipode-preserving  $g : \mathbf{S}^{n-1} \rightarrow \mathbf{S}^{n-1}$  were nullhomotopic. Then  $g$  would be extendable to a  $G : \mathbf{K}^n \rightarrow \mathbf{S}^{n-1}$ . Regarding  $\mathbf{K}^n$  as  $\mathbf{S}^n_+$ , we define  $\varphi : \mathbf{S}^n \rightarrow \mathbf{S}^{n-1}$  by

$$\varphi(x) = \begin{cases} G(x), & x \in \mathbf{S}^n_+, \\ -G\alpha(x), & x \in \mathbf{S}^n_-. \end{cases}$$

This is consistently defined on  $\mathbf{S}^n_+ \cap \mathbf{S}^n_-$ , and is an antipode-preserving map of  $\mathbf{S}^n$  to  $\mathbf{S}^{n-1}$ , contradicting (2).

(3) $\Rightarrow$ (4). Assume  $f : \mathbf{S}^n \rightarrow E^n$  is such that  $f(x) \neq f(-x)$  for every  $x \in \mathbf{S}^n$ . Define  $F : \mathbf{S}^n \rightarrow \mathbf{S}^{n-1}$  by

$$F(x) = \frac{f(x) - f(-x)}{\|f(x) - f(-x)\|}.$$

Then  $F|_{\mathbf{S}^{n-1}} : \mathbf{S}^{n-1} \rightarrow \mathbf{S}^{n-1}$  is antipode-preserving, and since  $F|_{\mathbf{S}^n_+}$  is an extension over  $\mathbf{K}^n$ ,  $F|_{\mathbf{S}^{n-1}}$  would be nullhomotopic, contradicting (3).

(4) $\Rightarrow$ (1). Assume there were some closed covering  $M_1, \dots, M_{n+1}$  of  $\mathbf{S}^n$  with no  $M_i$  containing a pair of antipodal points, i.e.,  $M_i \cap \alpha(M_i) = \emptyset$  for each  $i$ . Let  $g_i : \mathbf{S}^n \rightarrow \mathbf{I}$  be an Urysohn function with  $g_i|_{M_i} = 0$  and  $g_i|\alpha(M_i) = 1$  for each  $i = 1, \dots, n$ , and define  $g : \mathbf{S}^n \rightarrow E^n$  by

$$g(x) = (g_1(x), \dots, g_n(x)).$$

According to (4), there must be a  $z \in \mathbf{S}^n$  with  $g(z) = g\alpha(z)$ , so that  $g_i(z) = g_i(\alpha(z))$  for  $i = 1, \dots, n$ , and therefore  $z \in \mathbf{S}^n - \bigcup_{i=1}^n M_i - \bigcup_{i=1}^n \alpha(M_i)$ . Since both  $\{M_i\}_{i=1}^{n+1}$  and  $\{\alpha(M_i)\}_{i=1}^{n+1}$  cover  $\mathbf{S}^n$ , the point  $z$  must belong to both  $M_{n+1}$  and  $\alpha(M_{n+1})$ , which is the desired contradiction.  $\square$

## 6. Some Simple Consequences

We give two consequences of (5.2) that are particularly useful for our later work. The first relaxes the condition  $-f(x) = f(-x)$  in (5.2)(3) to simply  $f(x) \neq f(-x)$ ;

(6.1) THEOREM. *A map  $f : \mathbf{S}^n \rightarrow \mathbf{S}^n$  with  $f(x) \neq f\alpha(x)$  for each  $x$  is not nullhomotopic.*

PROOF. Since  $f(x) \neq f\alpha(x)$ , the map  $g : \mathbf{S}^n \rightarrow \mathbf{S}^n$  given by

$$x \mapsto \frac{f(x) - f(-x)}{\|f(x) - f(-x)\|}$$

is continuous and clearly antipode-preserving. Now,  $f, g : \mathbf{S}^n \rightarrow \mathbf{S}^n$  are never antipodal; for if  $g(z) = -f(z)$  for some  $z \in \mathbf{S}^n$ , then

$$[1 + \|f(z) - f(-z)\|]f(z) = f(-z),$$

so since  $\|f(z)\| = \|f(-z)\| = 1$ , we would have  $1 + \|f(z) - f(-z)\| = 1$ , which is impossible. Since  $f$  and  $g$  are never antipodal,

$$h_t(x) = \frac{(1-t)f(x) + tg(x)}{\|(1-t)f(x) + tg(x)\|}$$

is a well defined pont of  $\mathbf{S}^n$  for all  $(t, x) \in [0, 1] \times \mathbf{S}^n$  and hence  $\{h_t\}_{0 \leq t \leq 1}$  is a homotopy joining  $f$  and  $g$ . From this, since  $g$  is not nullhomotopic by (5.2)(3), we infer that neither is  $f$ . This completes the proof.  $\square$

The reader can easily show that in fact, (6.1) is equivalent to (5.2)(3).

The second consequence, which we shall use frequently, is Borsuk's fixed point theorem:

(6.2) THEOREM (Borsuk). *Let  $U$  be a bounded symmetric convex open neighborhood of the origin in  $E^n$ , and let  $F : \bar{U} \rightarrow E^n$  be antipode-preserving on  $\partial U$ , i.e.,  $-F(a) = F(-a)$  for each  $a \in \partial U$ . Then  $F$  has a fixed point.*

PROOF. Let  $p : E^n \rightarrow \mathbf{R}$  be the Minkowski functional for  $U$ , and let  $E$  be the set  $E^n$  with the norm  $\|x\|_1 = p(x)$ . The identity map  $h : E^n \rightarrow E$  is a homeomorphism mapping  $\bar{U}$  onto the unit ball  $\mathbf{K}_1^n$  of  $E$ . Considering the map  $g = h \circ F \circ h^{-1} : \mathbf{K}_1^n \rightarrow E$ , which is antipode-preserving on  $\partial \mathbf{K}_1^n$ , we

first show that  $g$  has a fixed point; for if  $g(x) \neq x$  in  $\mathbf{K}_1^n$ , then

$$f(x) = \frac{g(x) - x}{\|g(x) - x\|_1}$$

would be a continuous map  $f : \mathbf{K}_1^n \rightarrow \partial\mathbf{K}_1^n$ , so that  $f|\partial\mathbf{K}_1^n : \partial\mathbf{K}_1^n \rightarrow \partial\mathbf{K}_1^n$  would be nullhomotopic; but  $f|\partial\mathbf{K}_1^n$  is easily seen to be antipode-preserving and this is a contradiction. Therefore,  $hFh^{-1}(x) = x$  for some  $x \in \mathbf{K}_1^n$ , so that  $Fh^{-1}(x) = h^{-1}(x)$  and  $F$  has a fixed point.  $\square$

### 7. Brouwer's Theorem

The following special case of Borsuk's theorem (5.2)(3) is basic in fixed point theory.

(7.1) THEOREM. *The identity map  $\text{id} : \mathbf{S}^n \rightarrow \mathbf{S}^n$  is not homotopic to a constant map.*

PROOF. Since  $\text{id} : \mathbf{S}^n \rightarrow \mathbf{S}^n$  is antipode-preserving, (5.2)(3) applies.  $\square$

This result has many equivalent formulations; it is in fact equivalent to Brouwer's fixed point theorem:

(7.2) THEOREM. *The following statements are equivalent:*

- (1)  $\mathbf{S}^n$  is not contractible in itself.
- (2) (Bohl) Every continuous  $F : \mathbf{K}^{n+1} \rightarrow E^{n+1}$  has at least one of the following properties:
  - (a)  $F$  has a fixed point,
  - (b) there are  $x \in \partial\mathbf{K}^{n+1}$  and  $\lambda \in (0, 1)$  such that  $x = \lambda F(x)$ .
- (3) (Brouwer) Every continuous  $F : \mathbf{K}^{n+1} \rightarrow \mathbf{K}^{n+1}$  has at least one fixed point.
- (4) (Borsuk) There is no retraction  $r : \mathbf{K}^{n+1} \rightarrow \mathbf{S}^n$ , i.e., there is no continuous  $r : \mathbf{K}^{n+1} \rightarrow \mathbf{S}^n$  that keeps each  $x \in \mathbf{S}^n$  fixed.

PROOF. (1) $\Rightarrow$ (2). Suppose  $F(x) \neq x$  for all  $x \in \mathbf{K}^{n+1}$ , and  $y \neq tF(y)$  for all  $0 < t < 1$ ,  $y \in \partial\mathbf{K}^{n+1}$ ; then  $y \neq tF(y)$  also for  $t = 0$ , and by our first hypothesis, for  $t = 1$ . Let  $r : E^{n+1} - \{0\} \rightarrow \mathbf{S}^n$  be the map  $x \mapsto x/\|x\|$ . Then  $H : \mathbf{S}^n \times \mathbf{I} \rightarrow \mathbf{S}^n$  defined by

$$H(y, t) = \begin{cases} r(y - 2tF(y)), & 0 \leq t \leq \frac{1}{2}, \\ r[(2 - 2t)y - F\{(2 - 2t)y\}], & \frac{1}{2} \leq t \leq 1, \end{cases}$$

would show that  $\text{id} : \mathbf{S}^n \rightarrow \mathbf{S}^n$  is homotopic to a constant.

(2) $\Rightarrow$ (3). The second possibility in (2) cannot occur, because  $F(\mathbf{S}^n) \subset \mathbf{K}^{n+1}$ .

(3) $\Rightarrow$ (4). If there were a retraction, the map  $x \mapsto -r(x)$  would be a fixed point free map of  $\mathbf{K}^{n+1}$  into itself.

(4) $\Rightarrow$ (1). Assume  $h : 0 \simeq \text{id}$ , where  $h(\mathbf{S}^n, 0) = x_0 \in \mathbf{S}^n$ . Defining  $r : \mathbf{K}^{n+1} \rightarrow \mathbf{S}^n$  by

$$r(x) = \begin{cases} x_0, & \|x\| \leq \frac{1}{2}, \\ h(x/\|x\|, 2\|x\| - 1), & \|x\| \geq \frac{1}{2}, \end{cases}$$

would give a retraction of  $\mathbf{K}^{n+1}$  onto  $\mathbf{S}^n$ .  $\square$

The following example shows that Brouwer's theorem (7.2)(3) cannot be extended to infinite-dimensional normed linear spaces.

EXAMPLE. Let  $E$  be a noncomplete normed linear space, and  $K$  its closed unit ball. By (4.3.10) there is a deleting homeomorphism  $h : E \approx E - \{0\}$  such that  $h(x) = x$  for all  $x \in \partial K$ . Consider the map  $r : K \rightarrow \partial K$  given by  $x \mapsto h(x)/\|h(x)\|$ , which is well defined because  $h(y) \neq 0$  for all  $y \in E$ . If  $x \in \partial K$ , then  $h(x) = x$ , so  $r|_{\partial K} = \text{id}$  and  $r : K \rightarrow \partial K$  is a retraction; the map  $x \mapsto -r(x)$  is therefore a fixed point free map of  $K$  into itself.

This example shows that to obtain any generalization of the Brouwer fixed point theorem valid in infinite-dimensional spaces, it is necessary to restrict the type of map  $F : K \rightarrow K$  that will be considered. We will show in the next paragraph that every compact map  $F : K \rightarrow K$  (i.e., a continuous map such that  $\overline{F(K)}$  is compact) of the unit ball  $K$  of any normed linear space has a fixed point. Note that this statement, valid in all normed linear spaces, is precisely the Brouwer theorem whenever the space  $E$  is finite-dimensional, since in that case a continuous  $F : K \rightarrow K$  is necessarily compact. On this basis, it appears that for infinite-dimensional normed linear spaces, the natural analogue of a continuous map in finite-dimensional normed spaces is that of a compact (rather than simply continuous) map; maps of this type arise naturally in many problems of analysis.

## 8. Topological KKM-Principle

Among the results equivalent to Brouwer's fixed point theorem, the theorem of Knaster–Kuratowski–Mazurkiewicz occupies a special place: it admits an infinite-dimensional version which, as shown by Ky Fan, is particularly suitable for applications.

Let  $E$  be a vector space and  $X \subset E$  an arbitrary subset. Recall that a set-valued map  $G : X \rightarrow 2^E$  is called a *KKM-map* provided  $\text{conv}\{x_1, \dots, x_s\} \subset \bigcup_{i=1}^s Gx_i$  for each finite subset  $\{x_1, \dots, x_s\} \subset X$ ;  $G$  is called *strongly KKM* provided  $x \in Gx$  for each  $x \in X$  and the cofibers of  $G$  (i.e., the sets  $\{x \in X \mid y \notin Gx\}$  for  $y \in E$ ) are all convex.

The basic topological property of KKM-maps is given in

(8.1) THEOREM. *Let  $E$  be a linear topological space,  $X$  an arbitrary subset of  $E$ , and  $G : X \rightarrow 2^E$  a KKM-map such that each  $Gx$  is finitely*

*closed. Then the family  $\{Gx \mid x \in X\}$  has the finite intersection property.*

PROOF. We argue by contradiction, so assume  $\bigcap_{i=1}^n Gx_i = \emptyset$ . Working in the finite-dimensional flat  $L$  spanned by  $\{x_1, \dots, x_n\}$ , let  $d$  be the Euclidean metric in  $L$  and  $C = \text{conv}\{x_1, \dots, x_n\} \subset L$ ; note that because each  $L \cap Gx_i$  is closed in  $L$ , we have  $d(x, L \cap Gx_i) = 0$  if and only if  $x \in L \cap Gx_i$ . Since  $\bigcap_{i=1}^n L \cap Gx_i = \emptyset$  by assumption, the function  $\lambda : C \rightarrow \mathbf{R}$  given by  $c \mapsto \sum_{i=1}^n d(c, L \cap Gx_i)$  is not zero for any  $c \in C$ , and we can define a continuous  $f : C \rightarrow C$  by setting

$$f(c) = \frac{1}{\lambda(c)} \sum_{i=1}^n d(c, L \cap Gx_i) \cdot x_i.$$

By Brouwer's theorem,  $f$  would have a fixed point  $c_0 \in C$ . Let

$$I = \{i \mid d(c_0, L \cap Gx_i) \neq 0\}.$$

Then the fixed point  $c_0$  cannot belong to  $\bigcup\{Gx_i \mid i \in I\}$ ; however,

$$c_0 = f(c_0) \in \text{conv}\{x_i \mid i \in I\} \subset \bigcup\{Gx_i \mid i \in I\},$$

and with this contradiction, the proof is complete. □

As an immediate consequence of (8.1), we obtain the following fundamental result:

(8.2) THEOREM (Topological KKM-principle). *Let  $E$  be a linear topological space,  $X \subset E$  an arbitrary subset, and  $G : X \rightarrow 2^E$  a KKM-map. If all the sets  $Gx$  are closed in  $E$ , and if one of them is compact, then  $\bigcap\{Gx \mid x \in X\} \neq \emptyset$ .* □

Clearly, the topological KKM-principle contains as a special case the geometric KKM-principle (3.1.5). We now give two simple applications that do not follow from the geometric principle.

(8.3) THEOREM. *Let  $C$  be a nonempty compact convex set in a Hilbert space  $H$  with scalar product  $(\cdot, \cdot)$ , and let  $f : C \rightarrow H$  be continuous. Then there exists a  $y_0 \in C$  such that*

$$(f(y_0), y_0 - x) \leq 0 \quad \text{for all } x \in C.$$

PROOF. Define  $G : C \rightarrow 2^C$  by

$$Gx = \{y \in C \mid (f(y), y - x) \leq 0\}.$$

Clearly,  $G$  is strongly KKM, and hence, because  $C$  is convex, it is a KKM-map (see (3.1.2)). Since  $f$  is continuous, the sets  $Gx$  are closed, therefore compact. By the topological KKM-principle, we find a point  $y_0 \in C$  such that  $y_0 \in Gx$  for all  $x \in C$ , which is the required conclusion. □

As an immediate consequence, we have

(8.4) THEOREM. *Let  $C$  be a nonempty compact convex set in a Hilbert space  $H$ . Let  $F : C \rightarrow H$  be continuous and such that for each  $x \in C$  with  $x \neq F(x)$  the line segment  $[x, F(x)]$  contains at least two points of  $C$ . Then  $F$  has a fixed point.*

PROOF. Define  $f : C \rightarrow H$  by  $f(x) = x - F(x)$  for  $x \in C$ . By (8.3) we find a point  $y_0 \in C$  such that

$$(*) \quad (y_0 - F(y_0), y_0 - x) \leq 0 \quad \text{for all } x \in C.$$

We show that  $y_0$  is a fixed point of  $F$ . Indeed, if not, then the segment  $[y_0, F(y_0)]$  must contain a point of  $C$  other than  $y_0$ , say  $x = ty_0 + (1-t)F(y_0)$  for some  $0 < t < 1$ ; then from (\*) we get  $(1-t)(y_0 - F(y_0), y_0 - F(y_0)) \leq 0$ , and since  $t < 1$ , we must have  $y_0 = F(y_0)$ .  $\square$

The theorem just proved implies that any continuous self-map of a compact convex set in a Hilbert space has a fixed point, thus showing in particular that the Brouwer fixed point theorem is equivalent to the topological KKM-principle.

Numerous applications of the topological KKM-principle will be given in §7.

We conclude by observing that as a special case of (8.1) we obtain one of the basic results in fixed point theory:

(8.5) THEOREM (Knaster–Kuratowski–Mazurkiewicz). *Let  $X = \{x_0, \dots, x_n\}$  be the set of vertices of a simplex  $\sigma^n \subset \mathbf{R}^n$  and  $G : X \rightarrow 2^{\mathbf{R}^n}$  a KKM-map assigning to each  $x_i \in X$  a compact set  $Gx_i \subset \sigma^n$ . Then the intersection of the sets  $Gx_0, \dots, Gx_n$  is not empty.*  $\square$

We leave to the reader an easy proof that (8.1) and (8.5) are in fact equivalent.

## 9. Miscellaneous Results and Examples

*A. Homotopy, retraction, and extendability of maps*

(A.1) Let  $f, g : X \rightarrow \mathbf{S}^n$  be two maps. Show:

- (a) If  $f(x) \neq -g(x)$  for all  $x \in X$ , then  $f \simeq g$ .
- (b) If  $f(x) \neq g(x)$  for all  $x \in X$ , then  $f \simeq -g$ .
- (c) If  $f(x) \perp g(x)$  for all  $x \in X$ , then  $f \simeq g$ .

(A.2) Let  $f : \mathbf{S}^n \rightarrow \mathbf{S}^n$  be a map. Prove:

- (a) If  $f(x) \neq -x$  for all  $x \in \mathbf{S}^n$ , then  $f \simeq \text{id}_{\mathbf{S}^n}$ .
- (b) If  $f(x) \neq x$  for all  $x \in \mathbf{S}^n$ , then  $f \simeq \alpha$ , where  $\alpha : \mathbf{S}^n \rightarrow \mathbf{S}^n$  is the antipodal map.

(A.3) Let  $f, g : X \rightarrow \mathbf{S}^n$  be two maps such that  $f(x) \neq \pm g(x)$  for  $x \in X$ . Show: There is  $h : X \rightarrow \mathbf{S}^n$  such that  $g \simeq h$  and  $f(x) \perp h(x)$  for each  $x \in X$ .

[Take

$$h(x) = \frac{g(x) - (g(x), f(x))f(x)}{\|g(x) - (g(x), f(x))f(x)\|}.]$$

(A.4) Let  $X$  be any space and  $A \subset X$ . Show:  $A$  is a retract of  $X$  if and only if for every space  $Y$ , each  $f : A \rightarrow Y$  is extendable over  $X$ .

(A.5) Let  $\mathbf{K}^n$  be the unit ball in  $\mathbf{R}^n$  with boundary  $\mathbf{S}^{n-1}$ . Show:  $\mathbf{K}^n \times \{0\} \cup \mathbf{S}^{n-1} \times [0, 1]$  is a retract of  $\mathbf{K}^n \times [0, 1]$ .

[Consider  $r : \mathbf{K}^n \times [0, 1] \rightarrow \mathbf{K}^n \times \{0\} \cup \mathbf{S}^{n-1} \times [0, 1]$  given by

$$r(x, t) = \begin{cases} \left( \frac{x}{\|x\|}, 2 - \frac{2-t}{\|x\|} \right), & \|x\| \geq 1 - \frac{t}{2}, \\ \left( \frac{2x}{2-t}, 0 \right), & \|x\| \leq 1 - \frac{t}{2}. \end{cases}$$

(A.6) Let  $Y$  be any space and  $f_0, f_1 : \mathbf{S}^n \rightarrow Y$  be homotopic. Show: If  $f_0$  has an extension over  $\mathbf{K}^{n+1}$ , then so also does  $f_1$ .

[Use (A.4) and (A.5).]

*B. Borsuk's antipodal theorem*

(B.1) Let  $M_1, \dots, M_{n+2}$  be a closed covering of  $\mathbf{S}^n$  by  $n + 2$  nonempty sets. Show: If no  $M_i$  contains a pair of antipodal points, then  $M_1 \cap \dots \cap M_{n+2} = \emptyset$  and any  $(n + 1)$ -element subfamily has a nonempty intersection.

[If  $x \in M_1 \cap \dots \cap M_{n+2}$  then  $x \in \alpha(M_j)$  for some  $j$ , contradicting the assumption on  $M_j$ . For the second part: To show, say,  $M_1 \cap \dots \cap M_{n+1} \neq \emptyset$ , note that

$$\{M_1, \dots, M_{n+1}, \alpha(M_1), \dots, \alpha(M_{n+1})\}$$

must be a covering of  $\mathbf{S}^n$ , since an  $x$  not in the union must belong to both  $M_{n+2}$  and  $\alpha(M_{n+2})$ ; then apply (4.3).]

(B.2) Prove: In each decomposition of  $\mathbf{K}^{n+1}$  into  $n + 1$  closed sets, at least one of the sets must have diameter equal to 2.

[Use (4.4).]

(B.3) Prove the “invariance of dimension number” theorem:  $\mathbf{R}^m$  is not homeomorphic to  $\mathbf{R}^n$  whenever  $n \neq m$ .

[Suppose  $n > m$  and  $h : \mathbf{R}^n \rightarrow \mathbf{R}^m$  is a homeomorphism. Consider  $h|_{\mathbf{S}^{n-1}}$  and apply (5.2)(4).]

(B.4) Let  $f_1, \dots, f_n$  be  $n$  continuous real-valued functions on  $\mathbf{S}^n$ . Show: There exists at least one  $p \in \mathbf{S}^n$  with  $f_i(p) = f_i(-p)$  for all  $i \in [n]$ .

[Consider the map  $x \mapsto (f_1(x), \dots, f_n(x))$  of  $\mathbf{S}^n$  into  $\mathbf{R}^n$ .]

(B.5) Let  $f_1, \dots, f_n$  be  $n$  continuous real-valued functions on  $\mathbf{S}^n$  such that  $-f_i(p) = f_i(-p)$  for every  $p \in \mathbf{S}^n$ . Show: The  $f_i$  have a common zero on  $\mathbf{S}^n$ .

[Consider the proof of (5.2)(3) $\Rightarrow$ (4).]

(B.6) Let  $f_1, \dots, f_{n+2}$  be  $n + 2$  continuous real-valued functions on  $\mathbf{S}^n$  and assume that for each  $p \in \mathbf{S}^n$  there is at least one  $f_i$  with  $f_i(p) = 0 \neq f_i(-p)$ . Show: The  $f_1, \dots, f_{n+2}$  have no common zero, but any  $n + 1$  of them do.

[Use (B.1) with  $M_i = f_i^{-1}(0)$ .]

(B.7) Let  $f : \mathbf{S}^n \rightarrow \mathbf{S}^n$  be nullhomotopic. Show:  $f$  has a fixed point and sends some  $x$  to its antipode, i.e.,  $f(x_0) = -x_0$  for some  $x_0$ .

[If  $f$  has no fixed point, then  $f \simeq -\text{id}$ . If no point maps to its antipode, then  $f \simeq \text{id}$ , which is not nullhomotopic.]

### C. Theorem of Brouwer and related results

(C.1) Let  $X$  be a compact subset of  $\mathbf{R}^n$  with nonempty interior. Show: There is no retraction of  $X$  onto its boundary (Borsuk [1931]).

(C.2) (*Theorem on partitions*) Let  $\mathbf{J}^n$  be the  $n$ -cube  $\{(x_1, \dots, x_n) \mid |x_i| \leq 1 \text{ for } i \in [n]\}$ ; the  $i$ th face  $\{x \in \mathbf{J}^n \mid x_i = 1\}$  is denoted by  $\mathbf{J}_i^+$ , and the opposite face  $\{x \in \mathbf{J}^n \mid x_i = -1\}$  by  $\mathbf{J}_i^-$ . For each  $i \in [n]$  let  $A_i$  be a closed set separating  $\mathbf{J}_i^+$  and  $\mathbf{J}_i^-$  (i.e.,  $\mathbf{J}^n - A_i = U_i^+ \cup U_i^-$ , where the  $U_i^+, U_i^-$  are disjoint open sets with  $\mathbf{J}_i^+ \subset U_i^+$  and  $\mathbf{J}_i^- \subset U_i^-$ ). Prove:  $\bigcap_{i=1}^n A_i \neq \emptyset$  (Eilenberg–Otto [1938]; see also the book by Hurewicz–Wallman [1941]).

[For each  $i$  define

$$h_i(x) = \begin{cases} -d(x, A_i), & x \in U_i^+, \\ d(x, A_i), & x \in U_i^-, \end{cases}$$

and show that the map  $x \mapsto x + (h_1(x), \dots, h_n(x))$  maps  $\mathbf{J}^n$  into itself.]

(C.3) (*Miranda theorem*) Let  $f_1, \dots, f_n$  be continuous real-valued functions on  $\mathbf{J}^n$  such that for each  $i \in [n]$ ,

$$f_i(x) \geq 0 \quad \text{for } x \in \mathbf{J}_i^+, \quad f_i(x) \leq 0 \quad \text{for } x \in \mathbf{J}_i^-.$$

Show: There exists  $\hat{x} \in \mathbf{J}^n$  such that  $f_i(\hat{x}) = 0$  for each  $i \in [n]$  (Miranda [1940]).

(C.4) Let  $f : (\mathbf{K}^{n+1}, \mathbf{S}^n) \rightarrow (\mathbf{K}^{n+1}, \mathbf{S}^n)$  be a continuous map such that one of the following conditions holds: (a)  $\text{Fix}(f|_{\mathbf{S}^n}) = \emptyset$ , (b)  $f(x) = -x$  for each  $x \in \mathbf{S}^n$ , (c)  $f|_{\mathbf{S}^n} : \mathbf{S}^n \rightarrow \mathbf{S}^n$  is not nullhomotopic. Show:  $f : \mathbf{K}^{n+1} \rightarrow \mathbf{K}^{n+1}$  is surjective (Kuratowski–Steinhaus).

(C.5) (*Theorem of Frum-Ketkov and Nussbaum*) Let  $E$  be a Banach space and  $D$  a closed ball about the origin in  $E$ .

(a) Let  $f : D \rightarrow E$  be continuous with  $f(\partial D) \subset D$ . Show: If  $P : E \rightarrow E$  is a finite-dimensional linear projection with  $\|P\| = 1$ , then  $P \circ f : D \rightarrow E$  has a fixed point.

(b) Let  $K$  be a compact subset of  $E$ . By an *approximating sequence* for  $K$  is meant a sequence  $\{P_n\}$  of finite-dimensional linear projections in  $E$  such that (i)  $\|P_n\| = 1$  for all  $n$ ; (ii)  $P_n x \rightarrow x$  for each  $x \in K$ . Show: If  $\{P_n\}$  is an approximating sequence for  $K$ , then for each  $\varepsilon > 0$  there exists an integer  $n_\varepsilon$  such that  $P_n(K) \subset B_\varepsilon(K)$  for all  $n \geq n_\varepsilon$ .

(c) Let  $f : D \rightarrow E$  be continuous with  $f(\partial D) \subset D$  and assume that there exists a compact subset  $K$  of  $E$  that admits an approximating sequence  $\{P_n\}$  of projections and satisfies  $d(f(x), K) \leq \alpha d(x, K)$  for some  $\alpha < 1$  and all  $x \in D$ . Prove:  $f$  has a fixed point (Frum-Ketkov [1967], Nussbaum [1972a]).

[Establish successively the following assertions: for each  $n$  there is a fixed point  $x_n$  of  $P_n \circ f$ ; given  $\varepsilon > 0$ , we have  $(1 - \alpha)d(x_n, K) < \varepsilon$  for large  $n$  (use the definition of  $\alpha$  and (b)), implying  $d(x_n, K) \rightarrow 0$ ; there is a subsequence  $\{x_{n_i}\}$  converging to some  $x_0 \in K$ . Then  $f(x_0) = x_0$ .]

### D. Sperner's lemma and the Knaster–Kuratowski–Mazurkiewicz theorem

Let  $\Delta^n = [p_0, \dots, p_n]$  be an  $n$ -simplex. By a *subdivision*  $\mathcal{S}$  of  $\Delta^n$  is meant a decomposition of  $\Delta^n$  into finitely many nonoverlapping  $n$ -simplices  $\sigma_1, \dots, \sigma_k$  such that (1) the

intersection of any two simplices in  $\mathcal{S}$  is either empty, or a common face of each, and (2) each  $(n - 1)$ -simplex in  $\mathcal{S}$  that is not on  $\partial\Delta^n$  is the common face of exactly two  $n$ -simplices of  $\mathcal{S}$ . The *mesh* of  $\mathcal{S}$  is  $\max\{\text{diam } \sigma_i^v \mid i \in [k]\}$ ; the *carrier* of a vertex  $v \in \mathcal{S}$  is the lowest-dimensional face  $[p_{i_0}, \dots, p_{i_s}]$  of  $\Delta^n$  that contains  $v$ .

(D.1) Prove: Subdivisions of  $\Delta^n$  having arbitrarily small mesh exist.

[Use repeated barycentric subdivision (cf. III, 8.2).]

(D.2) (*Sperner's lemma*) Let  $\mathcal{S}$  be a subdivision of  $\Delta^n$ . A labeling of the vertices of  $\mathcal{S}$  that assigns to each vertex  $v \in \mathcal{S}$  one of the letters  $\{p_{i_0}, \dots, p_{i_s}\}$  whenever  $[p_{i_0}, \dots, p_{i_s}]$  is the carrier of  $v$ , is called a *Sperner labeling* of  $\mathcal{S}$ . Given a Sperner labeling of  $\mathcal{S}$ , an  $n$ -simplex  $\sigma_i \in \mathcal{S}$  is called *complete* if its vertices are labeled  $p_0, \dots, p_n$ . Prove: In any Sperner labeling of  $\mathcal{S}$ , the number of complete simplices is odd (and therefore at least one will exist) (Sperner [1928]).

[The result being trivial for  $n = 0$ , proceed by induction, assuming that it is true for every  $\Delta^{n-1}$ . Given a Sperner labeling of a subdivision  $\mathcal{S}$  of  $\Delta^n$ , consider the set of  $(n - 1)$ -simplices labeled  $(p_0, \dots, p_{n-1})$ . These arise from the  $\alpha$   $n$ -simplices of  $\mathcal{S}$  labeled  $(p_0, \dots, p_{n-1}, p_i)$ ,  $p_i \neq p_n$ , and the  $\beta$  complete simplices. Each of the  $\alpha$  simplices has 2 faces labeled  $(p_0, \dots, p_{n-1})$  and each complete  $n$ -simplex only 1, so counting the  $n$ -simplices of  $\mathcal{S}$ , we get a total of  $2\alpha + \beta$  simplices labeled  $(p_0, \dots, p_{n-1})$ . This total is precisely that of the  $\gamma$   $(n - 1)$ -simplices  $(p_0, \dots, p_{n-1})$  in the interior of  $\Delta^n$ , each counted twice, and the  $\delta$  such simplices on  $\partial\Delta^n$ , so  $2\alpha + \beta = 2\gamma + \delta$ . Now, the  $\delta$  simplices necessarily belong to the face  $(p_0, \dots, p_{n-1})$  of  $\Delta^n$ , and are the complete simplices in a Sperner labeling of a subdivision of that face. By the induction hypothesis,  $\delta$  is therefore odd, so  $\beta$  is odd. This completes the inductive step.]

(D.3) (*Knaster–Kuratowski–Mazurkiewicz theorem*) Let  $\Delta^n = [p_0, \dots, p_n]$  be an  $n$ -simplex, and let  $M_0, \dots, M_n$  be  $n + 1$  closed sets such that  $[p_{i_0}, \dots, p_{i_s}] \subset M_{i_0} \cup \dots \cup M_{i_s}$  for each subset  $\{i_0, \dots, i_s\} \subset \{0, \dots, n\}$ . Prove:  $\bigcap_{i=0}^n M_i \neq \emptyset$  (Knaster–Kuratowski–Mazurkiewicz [1929]).

$\{M_0, \dots, M_n\}$  is a closed covering of  $\Delta^n$  and  $p_i \in M_i$  for each  $i$ . Let  $\lambda > 0$  be a Lebesgue number for  $\{M_i\}$ , so that if  $A \subset \Delta^n$  is any set with  $\delta(A) < \lambda$ , then  $\bigcap\{M_i \mid M_i \cap A \neq \emptyset\} \neq \emptyset$ . Let  $\mathcal{S}$  be a subdivision of  $\Delta^n$  with mesh  $< \lambda$ . If  $v$  is any vertex of  $\mathcal{S}$ , choose the carrier  $[p_{i_0}, \dots, p_{i_s}]$  of  $v$ , and give  $v$  any one of the labels  $\{p_{i_0}, \dots, p_{i_s}\}$  such that  $v \in M_{i_r}$ . Apply (D.2).]

(D.4) Let  $\Delta^n = [p_0, \dots, p_n]$  be an  $n$ -simplex, and let  $\{M_i \mid i = 0, \dots, n\}$  be a closed covering of  $\Delta^n$  such that  $[p_0, \dots, \widehat{p}_i, \dots, p_n] \cap M_i = \emptyset$  for each  $i = 0, \dots, n$ . Prove:  $\bigcap_{i=0}^n M_i \neq \emptyset$ .

[Let  $X = \{p_0, \dots, p_n\} \subset \mathbf{R}^n$  and show that  $p_i \mapsto M_i$  is a KKM-map.]

(D.5) Let  $\Delta^n = [p_0, \dots, p_n]$  be an  $n$ -simplex, and let  $\{M_i \mid i = 0, \dots, n\}$  be a closed covering such that  $[p_0, \dots, \widehat{p}_i, \dots, p_n] \subset M_i$  for each  $i = 0, \dots, n$ . Prove:  $\bigcap_{i=0}^n M_i \neq \emptyset$  (Alexandroff–Pasynkoff [1957]).

[For each  $i = 0, \dots, n - 1$ , let  $M'_i = M_{i+1}$  and  $M'_n = M_0$ . Apply (D.3) by showing that  $p_i \mapsto M'_i$  is KKM.]

(D.6) Let  $\Delta^n = [p_0, \dots, p_n]$  be an  $n$ -simplex. Show that there exists a  $\lambda > 0$  with the property: If  $\mathcal{H}$  is any finite closed covering of  $\Delta^n$  and if each  $H \in \mathcal{H}$  has diameter  $< \lambda$ , then there are at least  $n + 1$  sets in  $\mathcal{H}$  that have a nonempty intersection (Lebesgue).

[Let  $\Delta_i = [p_0, \dots, \widehat{p}_i, \dots, p_n]$ ; since  $\bigcap_{i=0}^n \Delta_i = \emptyset$ , they have a Lebesgue number  $\lambda > 0$ : any set in  $\Delta^n$  of diameter  $< \lambda$  does not meet at least one  $\Delta_i$ . Assume that the sets of  $\mathcal{H}$  have diameter  $< \lambda$ . Define  $\Phi_0$  to be all the sets in  $\mathcal{H}$  that do not meet  $\Delta_0$ , and

proceeding recursively, let  $\Phi_k$  be the family of all sets in  $\mathcal{H} - \bigcup_{i=1}^{k-1} \Phi_i$  that do not meet  $\Delta_k$ ,  $k = 0, 1, \dots, n$ . Then  $\bigcup_{i=0}^n \Phi_i = \mathcal{H}$ , each  $H \in \mathcal{H}$  belongs to at least one  $\Phi_i$ , and the  $n + 1$  closed sets  $M_i = \bigcup\{H \mid H \in \Phi_i\}$  satisfy the conditions in (D.4).]

(D.7) Prove:  $\partial\Delta^n$  is not a retract of  $\Delta^n$ .

[If  $r : \Delta^n \rightarrow \partial\Delta^n$  were a retraction, consider the sets  $M_i = r^{-1}[p_0, \dots, \widehat{p}_i, \dots, p_n]$  and apply (D.5).]

(D.8) Let  $\Delta^n = [p_0, \dots, p_n]$  be an  $n$ -simplex, and let  $U_0, U_1, \dots, U_n$  be  $n + 1$  open sets in  $\Delta^n$  such that  $[p_{i_0}, \dots, p_{i_s}] \subset U_{i_0} \cup \dots \cup U_{i_s}$  for each subset  $\{i_0, \dots, i_s\} \subset \{0, \dots, n\}$ . Prove:  $\bigcap_{i=0}^n U_i \neq \emptyset$  (Lassonde [1990]).

### E. Universal maps

(E.1) Let  $X, Y$  be topological spaces. A map  $f : X \rightarrow Y$  is called *universal* if for any  $g : X \rightarrow Y$  there exists  $x \in X$  such that  $f(x) = g(x)$ . Recall that a space  $X$  is called a *fixed point space* if every continuous  $f : X \rightarrow X$  has a fixed point. Show:

- If  $f : X \rightarrow Y$  is universal, then  $f(X) = Y$ .
- If  $f : X \rightarrow Y$  is universal, then  $Y$  is a fixed point space.
- $X$  is a fixed point space if and only if  $\text{id}_X$  is universal.
- If  $gf$  is universal then so is  $g$ .
- Let  $A \subset X$  and  $f : X \rightarrow Y$ . If  $f|_A : A \rightarrow Y$  is universal then so is  $f$ .
- Any continuous map  $f : X \rightarrow [0, 1]$  of a connected space onto  $[0, 1]$  is universal.
- Let  $Y$  be a connected linearly ordered space with the interval topology, with the minimal and maximal elements. Then any continuous map  $f : X \rightarrow Y$  of a connected space  $X$  onto  $Y$  is universal.

(E.2) Let  $X, Y$  be metric spaces and  $\varepsilon > 0$ . A continuous  $f : X \rightarrow Y$  is called an  $\varepsilon$ -map if  $\delta(f^{-1}(y)) \leq \varepsilon$  for all  $y \in Y$ . Let  $X, Y$  be compact metric spaces and  $f : X \rightarrow Y$  be a map. Assume that for each  $\varepsilon > 0$  there exist a space  $Z_\varepsilon$  and an  $\varepsilon$ -map  $f_\varepsilon : Y \rightarrow Z_\varepsilon$  such that  $f_\varepsilon \circ f : X \rightarrow Z_\varepsilon$  is universal. Show:  $f$  is universal (Holsztyński [1969]).

(E.3) Let  $f : \mathbf{K}^{n+1} \rightarrow \mathbf{K}^{n+1}$  be a map such that  $f(\mathbf{S}^n) \subset \mathbf{S}^n$  and  $f|_{\mathbf{S}^n} : \mathbf{S}^n \rightarrow \mathbf{S}^n$  is not homotopic to a constant. Show:  $f$  is universal (Holsztyński [1969]).

(E.4) Let  $f : X \rightarrow \mathbf{K}^{n+1}$  be a map of a normal space into the  $(n + 1)$ -ball and  $A = f^{-1}(\mathbf{S}^n)$ . Prove:  $f$  is universal if and only if the map  $f|_A : A \rightarrow \mathbf{S}^n$  is not extendable over  $X$  (Lokutsievskii [1957], Holsztyński [1967]).

### F. Fixed point spaces

Given subsets  $A, B$  in a metric space  $(X, d)$  and  $\varepsilon > 0$ , an  $\varepsilon$ -displacement of  $A$  into  $B$  is any continuous map  $f_\varepsilon : A \rightarrow B$  such that  $d(a, f_\varepsilon(a)) \leq \varepsilon$  for all  $a \in A$ .

(F.1) Let  $(X, d)$  be a compact metric space and assume that for each  $\varepsilon > 0$ , there is an  $\varepsilon$ -displacement  $p_\varepsilon : X \rightarrow X$  such that  $p_\varepsilon(X)$  is a fixed point space. Show:  $X$  is a fixed point space (Borsuk [1932]).

(F.2) Let  $X$  be a compact metric space and assume that for each  $\varepsilon > 0$  there is an  $\varepsilon$ -map  $f : X \rightarrow \mathbf{K}^{n+1}$  onto some  $(n + 1)$ -ball such that  $f|_A : A \rightarrow \mathbf{S}^n$ , where  $A = f^{-1}(\mathbf{S}^n)$ , is not extendable over  $X$ . Prove:  $X$  is a fixed point space (Lokutsievskii [1957]).

(F.3) Show: The Hilbert cube  $\mathbf{I}^\infty$  is a fixed point space.

[Use (F.1) and the Brouwer fixed point theorem.]

(F.4) Let  $(X, d)$  be a metric space and  $\mathcal{K}(X)$  the set of all nonempty compact subsets of  $X$ . For  $A \in \mathcal{K}(X)$  and  $\varepsilon > 0$  we denote by  $U_\varepsilon(A)$  the  $\varepsilon$ -neighborhood of the set  $A$  in  $X$ . We define the *Borsuk metric*  $D_B$  in  $\mathcal{K}(X)$  by letting, for  $A, B \in \mathcal{K}(X)$ ,

$$D_B(A, B) = \inf_{\varepsilon} \{ \text{there are } \varepsilon\text{-displacements } f_\varepsilon : A \rightarrow U_\varepsilon(B) \text{ and } g_\varepsilon : B \rightarrow U_\varepsilon(A) \}.$$

Prove: If  $\{A_n\}$  is a sequence of fixed point spaces in  $\mathcal{K}(X)$  and  $D_B(A_n, A) \rightarrow 0$ , then  $A$  is also a fixed point space.

(F.5) Prove: The unit ball

$$\mathbf{K}^\infty = \left\{ x = \{x_i\} \in l^2 \mid \|x\|^2 = \sum_{i=1}^{\infty} x_i^2 \leq 1 \right\}$$

in the Hilbert space  $l^2$  is not a fixed point space (Kakutani [1943]).

[Show that  $\varphi : \mathbf{K}^\infty \rightarrow \mathbf{K}^\infty$  given by  $(x_1, x_2, \dots) \mapsto (\sqrt{1 - \|x\|^2}, x_1, x_2, \dots)$  is a continuous map without fixed points.]

(F.6) Let  $X$  be a normal space and  $L$  a closed subset of  $X$  homeomorphic to the half-line  $[1, \infty)$ . Show:  $X$  is not a fixed point space (Klee [1955]).

[Prove that  $L$  is a retract of  $X$  using the Tietze–Urysohn theorem.]

(F.7) Let  $E$  be an infinite-dimensional normed linear space and  $K$  its closed unit ball. Prove:  $K$  is not a fixed point space (Dugundji [1955]).

[Define by induction a sequence  $\{e_n\}$  in  $\partial K$  such that  $\text{dist}(e_{n+1}, \text{span}(e_1, \dots, e_n)) = 1$ . Prove that  $L = [e_1, e_2] \cup [e_2, e_3] \cup \dots$  is closed in  $K$  and that  $L$  is homeomorphic to  $[1, \infty)$ ; then apply (F.6). The argument in this hint was suggested by V. Klee and independently by C. Bowszyc.]

### G. Vector fields

Let  $A \subset \mathbf{R}^{n+1}$ , and let  $F : A \rightarrow \mathbf{R}^{n+1}$  be a map; from  $F$  we obtain a *vector field*  $f : A \rightarrow \mathbf{R}^{n+1}$  by  $f(x) = x - F(x)$ . A zero of  $f$  is called also a *singularity* of  $f$ ; clearly, the singularities of  $f$  are precisely the fixed points of  $F$ .

(G.1) Let  $f, g : \mathbf{S}^n \rightarrow \mathbf{R}^{n+1} - \{0\}$  be two singularity free vector fields that are never opposite. Show:  $f \simeq g$ .

(G.2) Let  $f : (\mathbf{K}^{n+1}, \partial \mathbf{K}^{n+1}) \rightarrow (\mathbf{R}^{n+1}, \mathbf{R}^{n+1} - \{0\})$  be a vector field on  $\mathbf{K}^{n+1}$  without singular points on  $\partial \mathbf{K}^{n+1}$ . We say that  $f$  is *essential* if for any given  $g : (\mathbf{K}^{n+1}, \partial \mathbf{K}^{n+1}) \rightarrow (\mathbf{R}^{n+1}, \mathbf{R}^{n+1} - \{0\})$  satisfying  $g|_{\partial \mathbf{K}^{n+1}} = f|_{\partial \mathbf{K}^{n+1}}$  there is a singular point for  $g$ ;  $f$  is said to be *inessential* if  $f|_{\mathbf{S}^n}$  can be extended without singularities over  $\mathbf{K}^{n+1}$ . Show: A vector field  $f : (\mathbf{K}^{n+1}, \partial \mathbf{K}^{n+1}) \rightarrow (\mathbf{R}^{n+1}, \mathbf{R}^{n+1} - \{0\})$  is essential if and only if the map  $\varphi : \mathbf{S}^n \rightarrow \mathbf{S}^n$  defined by  $x \mapsto f(x)/\|f(x)\|$  is not nullhomotopic.

(G.3) Let  $f, g : (\mathbf{K}^{n+1}, \partial \mathbf{K}^{n+1}) \rightarrow (\mathbf{R}^{n+1}, \mathbf{R}^{n+1} - \{0\})$  be two homotopic vector fields. Prove: If  $f$  is essential, then so is  $g$ .

(G.4) Let  $f : (\mathbf{K}^{n+1}, \partial \mathbf{K}^{n+1}) \rightarrow (\mathbf{R}^{n+1}, \mathbf{R}^{n+1} - \{0\})$  be an essential vector field. Show: The vector field  $f|_{\partial \mathbf{K}^{n+1}} : \mathbf{S}^n \rightarrow \mathbf{R}^{n+1} - \{0\}$  points in every direction.

(G.5) Let  $f : (\mathbf{K}^{n+1}, \partial \mathbf{K}^{n+1}) \rightarrow (\mathbf{R}^{n+1}, \mathbf{R}^{n+1} - \{0\})$  be a vector field such that the vectors at antipodal points never have the same direction. Show:  $f$  is essential.

(G.6) Let  $f : \mathbf{K}^{n+1} \rightarrow \mathbf{R}^{n+1} - \{0\}$  be a nonsingular vector field on  $\mathbf{K}^{n+1}$ . Show: There is a pair of antipodal points on  $\mathbf{S}^n = \partial\mathbf{K}^{n+1}$  at which the vectors have the same direction.

(G.7) Show: There is no singularity free vector field  $f : \mathbf{K}^{n+1} \rightarrow \mathbf{R}^{n+1} - \{0\}$  on  $\mathbf{K}^{n+1}$  such that  $f$  is everywhere outward normal or everywhere inward normal on the boundary.

[If  $f : \mathbf{S}^n \rightarrow \mathbf{R}^{n+1} - \{0\}$  has no inward normal, then it can be deformed to a field that has outward normal everywhere.]

#### H. Topological theory of KKM-maps

In this subsection,  $C$  stands for a nonempty convex set in  $\mathbf{R}^s$  and  $X$  for a subset of  $C$ ; by  $\langle X \rangle$  we denote the set of finite subsets of  $X$ , and for  $A \in \langle X \rangle$  we let  $[A] = \text{conv } A$ . We recall that  $F : X \rightarrow 2^C$  is a KKM-map if  $[A] \subset \bigcup \{Fx \mid x \in A\}$  for each  $A \in \langle X \rangle$ . We say that a map  $T : X \rightarrow 2^C$  has the *matching property* if the condition

$$[A] \subset \bigcup \{Tx \mid x \in A\} \quad \text{for some } A \in \langle X \rangle$$

implies that

$$\bigcap \{Tx \cap [B] \mid x \in B\} \neq \emptyset \quad \text{for some } B \in \langle X \rangle.$$

(H.1) (“Closed” and “open” versions of the KKM-property) Prove: If  $F : X \rightarrow 2^C$  is a closed-valued (or an open-valued) KKM-map, then

$$\bigcap \{Fx \cap [A] \mid x \in A\} \neq \emptyset \quad \text{for each } A \in \langle X \rangle.$$

(H.2) (*Matching theorems*) Prove: If  $T : X \rightarrow 2^C$  is an open-valued (or a closed-valued) KKM-map, then  $T$  has the matching property.

[Use the map  $x \mapsto Fx = C - Tx$  and (H.1).]

(H.3) (*Fixed point theorems*) Let  $T : C \rightarrow 2^C$  be a convex-valued map with open fibers (or with closed fibers) such that for some  $A \in \langle C \rangle$ , we have  $Tx \cap A \neq \emptyset$  for all  $x \in [A]$ . Show:  $\text{Fix}(T) \neq \emptyset$ .

[Use (H.2) and the following observation: if  $T : C \rightarrow 2^C$  is convex-valued and  $R = T^{-1}$ , then, given any  $A \in \langle C \rangle$ , the following properties are equivalent: (i)  $Tx \cap A \neq \emptyset$  for each  $x \in [A]$ , (ii)  $[A] \subset \bigcup \{Rx \mid x \in A\}$ .]

(The above results, except the “closed” version of (H.1), are due to Lassonde [1990].)

## 10. Notes and Comments

### *The antipodal theorem of Borsuk*

This is one of the central results in fixed point theory. It was established by Borsuk [1933a] together with (4.4); the Borsuk–Ulam theorem was conjectured by Ulam and proved by Borsuk. Theorem (4.4) was discovered earlier by Lusternik–Schnirelmann [1930] in their work on topological methods in analysis.

The combinatorial proof of (5.2) presented in the text is an adaptation of that in Granas’s tract [1962]. The first proof of this type was given by Tucker [1945] for  $n = 3$ ; Fan [1952a] extended Tucker’s result to arbitrary  $n$

and established some generalizations of the Borsuk–Ulam and Lusternik–Schnirelmann–Borsuk theorems. A combinatorial proof of the antipodal theorem was also found by Krasnosel’skiĭ–Krein [1949]. The first proof of the antipodal theorem using the analytical definition of the degree was given in the lecture notes by J.T. Schwartz [1969]. For yet another analytical proof see the lecture notes by Nirenberg [1973]. An elementary proof based on degree theory may also be found in Dugundji’s book [1965]. A noteworthy algebraic proof of the Borsuk–Ulam theorem is given by Arason–Pfister [1982].



K. Borsuk and P. Alexandroff, Radachówka, 1962

### *The Lusternik–Schnirelmann category*

Let  $X$  be a topological space. A set  $A \subset X$  has *Lusternik–Schnirelmann category*  $\leq n$ , written  $\text{Cat } A \leq n$ , if  $A$  is the union of  $n$  closed sets each deformable to a point in  $X$ . It is easy to establish that:

- (a)  $\text{Cat } B \leq \text{Cat } A$  if  $B \subset A$ .
- (b)  $\text{Cat}(A \cup B) \leq \text{Cat } A + \text{Cat } B$ .
- (c)  $\text{Cat } A \leq \dim A - 1$ .
- (d) If  $f : A \rightarrow X$  is homotopic to the inclusion  $i : A \rightarrow X$ , then  $\text{Cat } A \leq \text{Cat}(f(A))$ .

The following theorem of Lusternik–Schnirelmann [1930] is equivalent to Theorem (4.4), and hence to Borsuk’s antipodal theorem: *If  $P^n$  is the  $n$ -dimensional real projective space, then  $\text{Cat}(P^n) = n + 1$ .*

This notion of category plays a basic role in the critical point theory developed by Lusternik–Schnirelmann. Let  $f$  be a smooth real-valued function on a smooth manifold  $M$ . A point  $p \in M$  is called a *critical point* of  $f$  provided there is a local coordinate system  $(x_1, \dots, x_n)$  in a nbd of  $p$  with  $\partial f(p)/\partial x_i = 0$  for all  $i = 1, \dots, n$ . The number of critical points is governed by the following fundamental result of Lusternik–Schnirelmann: *If  $M$  is compact, then  $f$  has at least  $\text{Cat } M$  critical points on  $M$ .*

The following is a simple application. Let  $f(x) = f(x_1, \dots, x_n)$  be a smooth function defined on a nbd of the unit sphere  $\mathbf{S}^{n-1}$  in  $\mathbf{R}^n$ . The critical points of  $f$  are determined by the equations

$$(*) \quad d\left[f(x) - \lambda \sum_{i=1}^n x_i^2\right] = 0, \quad \sum_{i=1}^n x_i^2 = 1$$

(if  $f$  is a quadratic form, then the corresponding critical points coincide with eigenvectors of  $f$ , and to Lagrange multipliers correspond eigenvalues of  $f$ ). Assume that the function  $f$  is even, i.e.,  $f(x) = f(-x)$  for all  $x \in \mathbf{S}^{n-1}$ . Since by identifying  $x$  with  $-x$  for all  $x \in \mathbf{S}^{n-1}$  we obtain the projective space  $P^{n-1}$ , it follows from the above theorem of Lusternik–Schnirelmann that  $f : P^{n-1} \rightarrow \mathbf{R}$  has at least  $\text{Cat}(P^{n-1}) = n$  different critical points and hence the equation  $(*)$  has at least  $n$  different pairs of solutions.

### *Results related to the Borsuk–Ulam theorem*

The Borsuk–Ulam theorem suggested deriving more precise results for maps  $f : \mathbf{S}^n \rightarrow \mathbf{R}$ . In 1942 Kakutani ( $n = 2$ ) and in 1950 Yamabe–Yujobô (for general  $n$ ) showed that there exist  $n + 1$  points  $\{x_i\}$  satisfying  $(x_i, x_j) = 0$  for  $i \neq j$  and such that  $f(x_1) = \dots = f(x_{n+1})$ . This has a consequence that *any compact convex  $K \subset \mathbf{R}^{n+1}$  has a circumscribing  $(n + 1)$ -cube  $C$  (i.e., every face of  $C$  meets  $K$ ): for each direction  $\alpha \in \mathbf{S}^n$  let  $f(\alpha)$  be the distance between two parallel planes perpendicular to  $\alpha$  that contain  $K$  between them, each of the planes meeting  $K$ .* In 1950 Dyson ( $n = 2$ ) and in 1954 Yang (arbitrary  $n$ ) showed that any  $f : \mathbf{S}^n \rightarrow \mathbf{R}$  maps the  $2n$  endpoints of some  $n$  mutually orthogonal diameters to a single point. For more details see Yang [1954].

### *Theorem of Brouwer*

This is one of the oldest and best known results in topology. It was proved for  $n = 3$  by Brouwer [1909]; for differentiable maps an equivalent result was established earlier by Bohl [1904]. Hadamard [1910] (using the Kronecker

index) gave an analytic proof for arbitrary  $n$ ; somewhat earlier, Brouwer gave a proof using the simplicial approximation technique and the notion of degree; that proof appeared in Brouwer [1912] (cf. comment on p. 277). Other proofs depending on various definitions of degree were also given by J.W. Alexander [1922] and Birkhoff–Kellogg [1922].

A simple combinatorial proof of the Brouwer theorem (based on Sperner’s lemma [1928]) was given by Knaster–Kuratowski–Mazurkiewicz [1929]; they noted also that for a map  $f : \mathbf{K}^n \rightarrow \mathbf{R}^n$  the condition  $f(\partial\mathbf{K}^n) \subset \mathbf{K}^n$  suffices for the existence of a fixed point. For a noteworthy analytical proof of the Brouwer theorem see Lax [1999]; for another proof due to Milnor [1978] see “Miscellaneous Results and Examples”.

### *Equivalent formulations*

The fact that the Brouwer fixed point theorem admits an equivalent formulation in terms of homotopy and another one in terms of retraction was observed by Borsuk [1931a], [1931b]; these simple but significant observations provided the justification for the study of nonextendability problems and were the starting point of many further important developments. The fact that there is no retraction  $r : \mathbf{K}^{n+1} \rightarrow \mathbf{S}^n$  (besides being equivalent to Brouwer’s theorem) provides a key to a number of other results in topology; it can be used, for example, to prove the domain invariance in  $\mathbf{R}^n$  and also the “tiling” covering theorem of Lebesgue (see the book of Hurewicz–Wallman [1941]). Among the proofs of this nonretraction result we mention an analytic proof by Milnor (cf. Milnor’s book [1965]) based on the approach of M. Hirsch [1963], the inductive proof by Sieklucki [1983], and that of Alexandroff–Pasynkoff [1957] based on the Knaster–Kuratowski–Mazurkiewicz theorem. For a discussion of the not entirely correct approach of Hirsch [1963] in the simplicial context see Joshi [2000].

### *Computing fixed points*

Brouwer’s theorem ensures that each self-map  $f : \sigma \rightarrow \sigma$  of a simplex has at least one fixed point. Until the late sixties computer methods to find a fixed point of a given such map were severely limited: the techniques used were all based on iterative procedures that required additional restrictions on the map in order to guarantee convergence. Scarf [1967] developed a finite algorithm (based essentially on Sperner’s lemma) for approximating a fixed point for any continuous  $f : \sigma \rightarrow \sigma$ ; to improve accuracy, the early programs included a Newton method subroutine, depending on the function considered. Scarf’s paper initiated considerable activity in computation of fixed points. By using homotopy techniques, Eaves [1972] gave an algorithm with improved accuracy over that of Scarf, and avoiding the Newton method:

working on  $\sigma \times \mathbf{I}$  with the given function on  $\sigma \times \{0\}$ , a known function with a unique fixed point on  $\sigma \times \{1\}$ , and a suitable homotopy joining them, this approach relies on the fact that connected 1-manifolds (the fibers of the homotopy) are homeomorphic either to the circle or to the unit interval. An introduction to this currently active research area and to some of its immediate applications may be found in Scarf–Hansen [1973] and the book of Allgower–Georg [1990].

### *Brouwer's theorem in the infinite-dimensional case*

The fact that the Brouwer theorem does not hold for arbitrary continuous maps of the unit ball in infinite-dimensional Banach spaces was observed by several authors.

In 1935 (answering a question of Ulam), Tychonoff showed that the unit sphere in  $l^2$  is a retract of the unit ball. Leray [1935] observed that the unit sphere in  $C[0, 1]$  is contractible. Kakutani [1943] gave an example of a fixed point free homeomorphism of the unit ball in  $l^2$  into itself. Dugundji [1951] proved the following theorem: *A closed unit ball in a normed linear space is a fixed point space if and only if it is compact.* Klee [1955] generalized this result to arbitrary convex sets in metrizable locally convex spaces.

In their study of fixed points of Lipschitz maps, Lin–Sternfeld [1985] established the following result: *A convex set in a Banach space, having the fixed point property for Lipschitz maps, must be compact.* From this one can deduce the following earlier result of Nowak [1979]: *In every infinite-dimensional Banach space there exists a Lipschitz retraction of the unit ball on its boundary.* For more details the reader is referred to Bessaga [1994] and to the book of Goebel–Kirk [1991].

### *Universal maps*

A map  $f : X \rightarrow Y$  is called *universal* if for each  $g : X \rightarrow Y$  there is  $x \in X$  such that  $f(x) = g(x)$  (clearly  $X$  is a fixed point space if and only if the identity map  $1_X$  is universal). This notion is due to Holsztyński [1964], who obtained the following generalizations of the theorems of Hurewicz and Brouwer:

- (i) *Let  $X$  be a normal space and  $\mathbf{J}_k^n = \{(x_1, \dots, x_n) \in \mathbf{J}^n \mid x_{|k|} = \text{sgn } k\}$  for  $k = \pm 1, \pm 2, \dots, \pm n$ , where  $\mathbf{J} = [-1, +1]$ . Let  $f : X \rightarrow \mathbf{J}^n$  be a map and  $A_1, \dots, A_n$  be a sequence of closed sets in  $X$  such that  $A_k$  partitions  $X$  between  $f^{-1}(\mathbf{J}_{-k}^n)$  and  $f^{-1}(\mathbf{J}_k^n)$  for  $k = 1, \dots, n$ . Then  $f$  is universal if and only if  $\bigcap_{i=1}^n A_i \neq \emptyset$ .*
- (ii) *If  $X$  is a normal space, then the covering dimension  $\dim X \geq n$  if and only if there is a universal map  $f : X \rightarrow \mathbf{J}^n$ .*

Further results (and some applications to dimension theory) can be found in Holsztyński [1967], [1969].

*Fixed point spaces*

A space  $X$  has the fixed point property (or is a fixed point space) if every continuous  $f : X \rightarrow X$  has a fixed point. Clearly, this property is topologically invariant. Borsuk [1931a] observed that if  $X$  is a fixed point space, so also is every retract of  $X$ . For Cartesian products of fixed point spaces, the result depends on the number of factors. The product of two compact fixed point spaces need not be a fixed point space. We mention the following examples:

- (i) there is a finite polyhedron  $P$  that is a fixed point space while  $P \times [0, 1]$  is not a fixed point space (see an example of Lopez [1967] given below and Bredon [1971]);
- (ii) there is a finite polyhedron  $P$  with the fixed point property such that the suspension of  $P$  is not a fixed point space (Holsztyński [1970]);
- (iii) there are two manifolds  $X, Y$  that are fixed point spaces while  $X \times Y$  is not a fixed point space (Husseini [1977]).

In contrast with finite products, an infinite product of compact nonempty fixed point spaces is a fixed point space whenever every finite product of those spaces is a fixed point space (Dyer [1956]). Thus by the Brouwer theorem, the Hilbert cube  $I^\infty$  and in fact any Tychonoff cube are fixed point spaces.

Several important results are summarized in the following list of fixed point spaces:

- (i) projective spaces of even dimension (J.W. Alexander [1922]),
- (ii) compact convex sets in  $L^2$  and in  $C^n[0, 1]$  (Birkhoff–Kellogg [1922]),
- (iii) compact convex sets in Banach spaces (Schauder [1927a], [1927b], [1930]),
- (iv) weakly compact convex sets in separable Banach spaces (with respect to weakly continuous maps) (Schauder [1927a]),
- (v) compact absolute retracts (Borsuk [1931a]),
- (vi) compact convex sets in locally convex linear topological spaces (Tychonoff [1935]).

Two compact metric spaces  $X$  and  $Y$  are *quasi-homeomorphic* if for each  $\varepsilon > 0$  there is an  $\varepsilon$ -map  $f : X \rightarrow Y$  and an  $\varepsilon$ -map  $g : Y \rightarrow X$ . The question of whether the fixed point property is invariant under quasi-homeomorphisms was treated by Borsuk [1938]: it is not invariant for arbitrary continua but is invariant if  $X$  and  $Y$  are compact ANRs.

*Some examples*

We give some noteworthy examples of continua lacking the fixed point property.

(a) (Knill [1967]) Let  $S = \{x \in \mathbf{R}^2 \mid \|x\| = 1\}$  be the unit circle and  $A$  be a closed half-line spiraling to  $S$ . Let  $X = A \cup S$  and regard  $X$  as a subset of  $\mathbf{R}^2 \times \{0\} \subset \mathbf{R}^3$ . Let  $Z = CX \subset \mathbf{R}^3$  be the cone over  $X$  with vertex  $p = (0, 0, -1)$  as shown in Figure 1. Clearly,  $Z$  is contractible (to  $p$ ); Knill showed that  $Z$  is not a fixed point space but is a cell-like continuum (i.e., it is the intersection of a decreasing sequence of closed 3-cells in  $\mathbf{R}^3$ ).

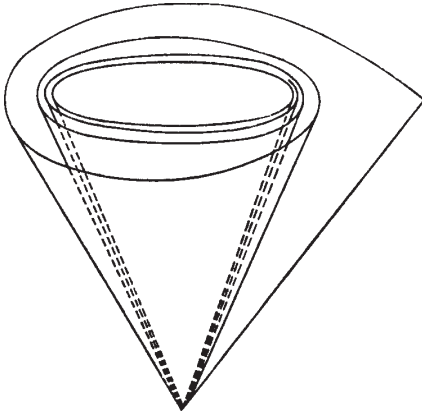

Figure 1

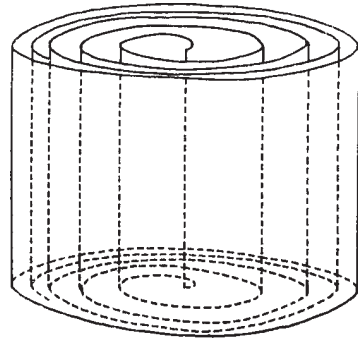

Figure 2

(b) (Kinoshita [1953]) Let  $X$  be the “can-with-a-roll-of-toilet-paper” shown in Figure 2. Clearly,  $X$  is a contractible continuum; Kinoshita showed that neither  $X$  nor the cone  $CX$  over  $X$  has the fixed point property. In connection with the above two examples see Sieklucki [1985].

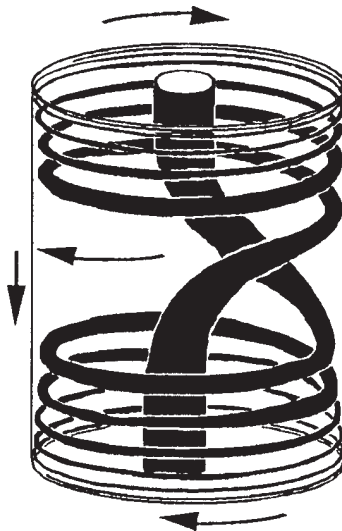

Figure 3

(c) (Borsuk [1935]) Let  $X$  be the continuum in  $\mathbf{R}^3$  shown in Figure 3. It consists of a solid cylinder with two tunnels carved out; the width of each tunnel tends to zero as the tunnel approaches the limiting circle. Borsuk showed that  $X$  is a cell-like continuum that admits a fixed point free homeomorphism. Such a homeomorphism can be described as follows: the top and the bottom of the cylinder rotate about the axis of the cylinder, and each point lying between the top and the bottom is moved down below its original position. Borsuk's example can be used to construct a fixed point free flow with bounded orbits in  $\mathbf{R}^3$  (Kuperberg–Reed [1981]). For related results, the reader is referred to Kuperberg et al. [1993]. We remark that there exists a 3-dimensional continuum in  $\mathbf{R}^4$  that has the properties of the Borsuk example and in addition is simply connected (Verchenko [1940]).

(d) Let  $X$  be a plane continuum not separating the plane. It can be shown that  $X$  is the intersection of a decreasing sequence of closed 2-cells in  $\mathbf{R}^2$ . Since the twenties, the following problem has remained unsolved: does  $X$  have the fixed point property? The following related partial result was established by Cartwright–Littlewood [1951]: *Let  $h$  be an orientation-preserving homeomorphism of  $\mathbf{R}^2$  onto itself, and let  $X = h(X)$  be a continuum not separating the plane. Then  $h|X$  has a fixed point.*

(e) (Lopez [1967]) We now describe a polyhedron  $Z$  with the fixed point property such that  $Z \times [0, 1]$  lacks this property. Let  $P^n(\mathbf{C})$  denote the complex  $n$ -dimensional projective space (of real dimension  $2n$ ). It is obtained from  $\mathbf{C}^{n+1} - \{0\}$  by identifying all the points on each complex line through 0 to any particular point. Specific embeddings  $P^n(\mathbf{C}) \subset P^{n+1}(\mathbf{C})$  can be obtained from the inclusions  $\mathbf{C}^{n+1} \times \{0\} \subset \mathbf{C}^{n+1} \times \mathbf{C}$ . The space  $P^1(\mathbf{C})$  is readily seen to be homeomorphic to the 2-sphere  $\mathbf{S}^2$ .

Let  $(a, b) \in \mathbf{S}^2 \times \mathbf{S}^2$  and form a quotient space  $Z$  of the disjoint union  $P^2(\mathbf{C}) + \mathbf{S}^2 \times \mathbf{S}^2 + P^4(\mathbf{C}) + \Sigma P^8(\mathbf{C})$  by identifying

$$\begin{aligned} \mathbf{S}^2 &= P^1(\mathbf{C}) \subset P^2(\mathbf{C}) && \text{with } \mathbf{S}^2 \times \{b\} \text{ in } \mathbf{S}^2 \times \mathbf{S}^2, \\ \mathbf{S}^2 &= P^1(\mathbf{C}) \subset P^4(\mathbf{C}) && \text{with } \{a\} \times \mathbf{S}^2 \text{ in } \mathbf{S}^2 \times \mathbf{S}^2, \end{aligned}$$

and  $(a, b)$  with any point of  $\Sigma P^8(\mathbf{C})$ , the suspension of  $P^8(\mathbf{C})$ .

The space  $Z$  is triangulable; Lopez showed that  $Z$  has the fixed point property but  $Z \times [0, 1]$  does not. This is another example showing that the fixed point property is not an invariant of homotopy type. Although not so easily visualized as example (a), it has the advantage of having no local pathology.

Further, more special examples of fixed point spaces and additional references can be found in the surveys by Bing [1969], Fadell [1970], and Brown [1974].